

# SINK MIXERS

100 Years of Innovation and Design  
A brand you can trust

Product Range 2011

KITCHEN  
SYSTEMS



SPIRIT OF  
FRANKE  
THE FIRST 100 YEARS

**FRANKE**

## INTRODUCING FRANKE'S NEW RANGE OF SINK MIXERS

(Enix Square, Highrise & Projectline)

### Elegant Design & Excellent Quality

Franke Kitchen Systems have introduced a new range of Sink Mixers. Each sink mixer has been carefully designed with the end user in mind, ensuring that they receive the highest quality components, with excellent back-up support - the trusted Franke Brand.



#### SMART LIME CLEANING AERATOR:\*

- Smart Lime Resistance – maximising the life-span of the aerator
- No need to disassemble the aerator for cleaning – simply rub the lime away using your finger
- Perfect stream quality even under difficult flow conditions
- Very low noise level
- High quality, the Smart Lime Cleaning Aerator cannot be crushed
- Integrated anti-clogging dome screen - filters sediments and particles

\*Excluding Enix Square



### MIXER ACCESSORIES

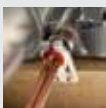

**TAP BRACE**  
Product Code:  
303020



**TAP HOLE CUTTER**  
Product Code:  
301355



**TAP HOLE STOPPER**  
Product Code:  
303043

## GUARANTEE

Franke Sink Mixers carry a 5 year guarantee on the body construction against manufacturing defects, with a 2 year guarantee on the cartridge.

All guarantee's are subject to proper installation and proof of purchase is required for all enquiries.

For all enquiries contact the Call Centre on 0861 372 653

## CARTRIDGE:

"Sedal" is the leading European manufacturer of Sink Mixer Cartridges in over 11 Countries.

### Features:

- Noise suppressor of 17-18 decibels
- Anti-scold set for standard operation can be reset. (Refer to registered plumber).
- Endurance test of 70,000 cycles, complies with EN 814 International Standards
- Reduced flow rate for green rating
- Suitable for balanced water pressure of 200 - 600kPa

## BRAIDED CONNECTORS:

- Stainless Steel braiding



- Cross-linked inner hose
- Brass nuts - 1/2 inch / 15mm

**NEW**



## ENIX SQUARE

### Features:

- Ceramic Disk Cartridge with Anti-scoold
- Solid DZR Brass Construction
- Chrome Plated
- 5 Year guarantee on body construction
- 2 Year guarantee on ceramic cartridge



Enix Square Swivel  
**Product Code: 305050**

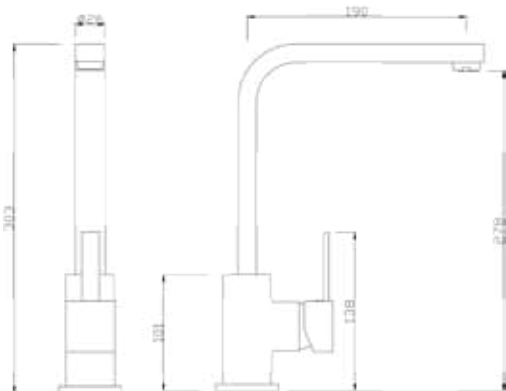

**NEW**



## HIGHRISE

### Features:

- Ceramic Disk Cartridge with Anti-scold
- Solid DZR Brass Construction
- Smart Lime Cleaning Aerator
- Chrome Plated
- 5 Year guarantee on body construction
- 2 Year guarantee on ceramic cartridge



High Rise Swivel

**Product Code: 305060**

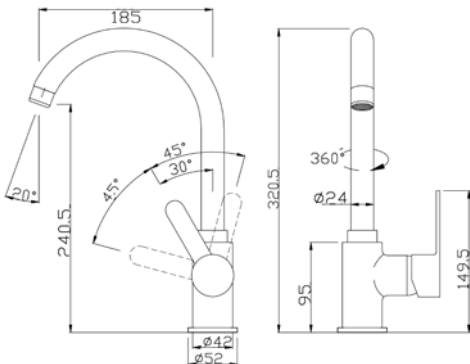

NEW



## TURCHESO

### Features:

- Ceramic Disk Cartridge
- Solid Brass Construction
- Chrome Plated
- 5 Year guarantee on body construction
- 2 Year guarantee on ceramic cartridge



Turcheso Swivel  
**Product Code: 305055**

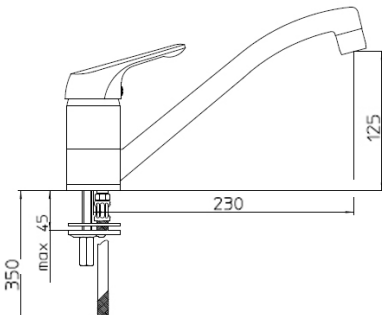

NEW



## PROJECTLINE

### Features:

- Ceramic Disk Cartridge with Anti-scald
- Solid DZR Brass Construction
- Smart Lime Cleaning Aerator
- Chrome Plated
- 5 Year guarantee on body construction
- 2 Year guarantee on ceramic cartridge



Projectline Single Lever  
**Product Code: 305065**

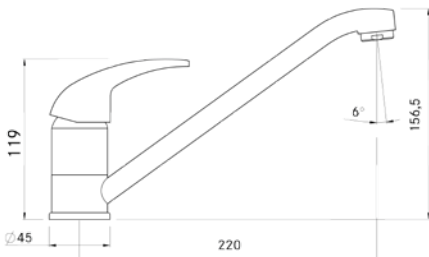



## KUBUS FILTERFLOW WATER PURIFICATION

Discover the unique advantages and health benefits of the Franke Kubus Filterflow water filtration system. Designed and manufactured by British engineers, and fitted with a premium-grade carbon activated cartridge, the Franke Kubus Filterflow is a health-conscious and quality drinking water filtration system.

### Features:

- Water Purification Filter
- Dispenses Hot, Cold and Filtered Water
- Carbon Activated Cartridge
- Solid Brass Construction
- Chrome Plated
- Removes Chlorine, Lead, Harmful Bacteria, Parasites and Cysts including Cryptosporidium
- Improves Taste, Odour and Colour
- Kubus Filterflow retains Beneficial Minerals such as Calcium and Magnesium - essential for a healthy diet
- Guaranteed for 5 Years on Body Construction





Kubus Swivel  
Product Code: 821054

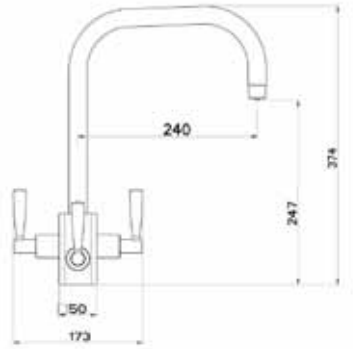

## KUBUS FILTERFLOW INSTALLATION

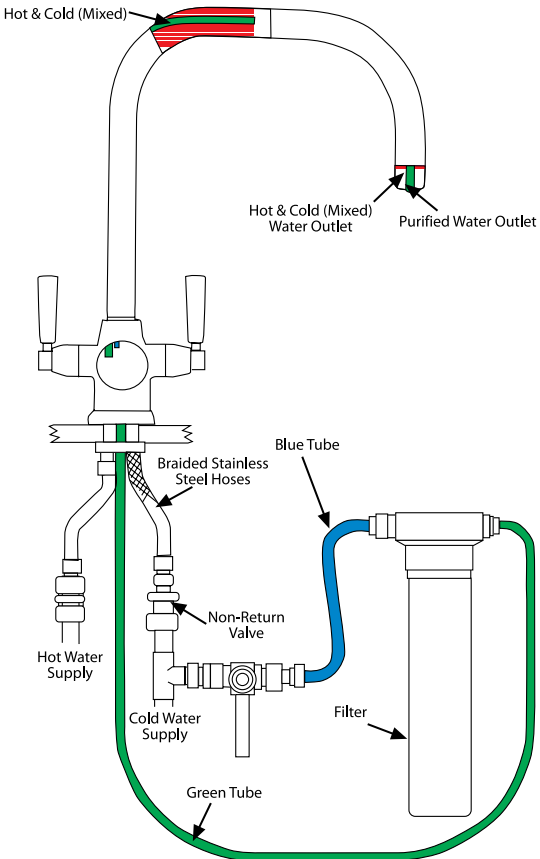



# SD80 SOAP DISPENSER

## Features:

- Manufacture from chromium plated brass
- Incorporates a replaceable 1 Litre polyethylene container for use with liquid soap
- 5 Year Warranty on Body



SD80 Soap Dispenser  
**Product Code: 359802**

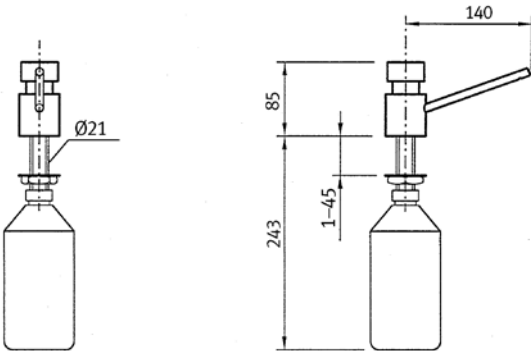



# BILLY

## Features:

- Ceramic Disk Cartridge
- Solid Brass Construction
- Chrome Plated
- 5 Year guarantee on body construction
- 2 Year guarantee on ceramic cartridge



Billy Joystick Professional  
Product Code: 303220

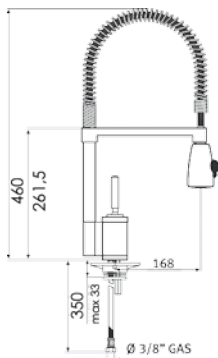

Billy Joystick Swivel  
Product Code: 303219

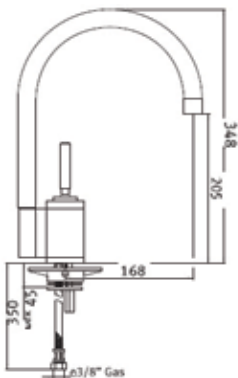



# DESIGNER

## Features:

- Ceramic Disk Cartridge
  - Solid Brass Construction
  - Chrome Plated
  - 5 Year guarantee on body construction
  - 2 Year guarantee on ceramic cartridge
- 



Designer Retractable  
**Product Code: 303225**

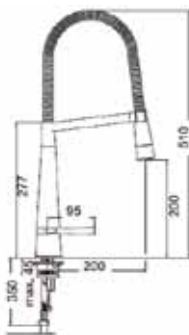

Designer Swivel  
**Product Code: 303224**

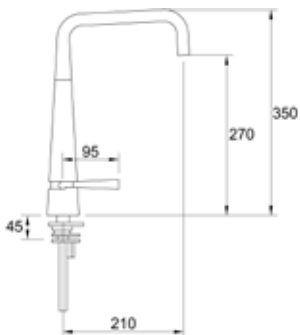





# ZODIACO

## Features:

- Ceramic Disk Cartridge
- Solid Brass Construction
- Chrome Plated
- 5 Year guarantee on body construction
- 2 Year guarantee on ceramic cartridge



Zodiaco Chrome - Swivel  
**Product Code: 303218**

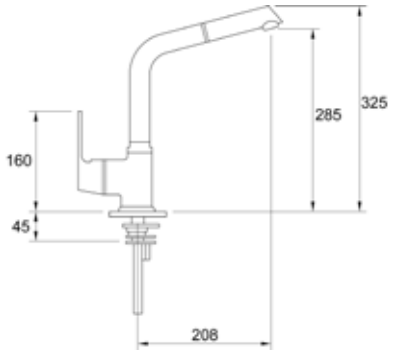

Zodiaco Chrome - Retractable  
**Product Code: 303217**

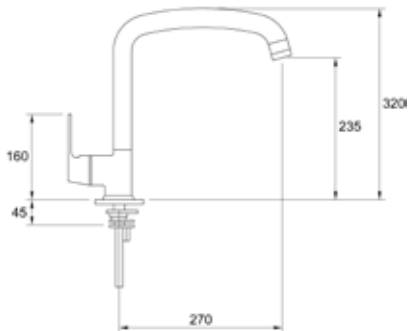



# ADMIRAL

## Features:

- Ceramic Disk Cartridge
- Graphite finish to compliment the Admiral and Mythos Sink Ranges
- 5 Year guarantee on body construction
- 2 Year guarantee on ceramic cartridge



Admiral Graphite - Retractable  
Product Code: 303221

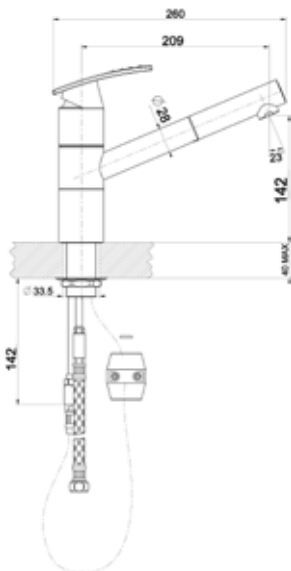

Admiral Graphite - Swivel  
Product Code: 303222

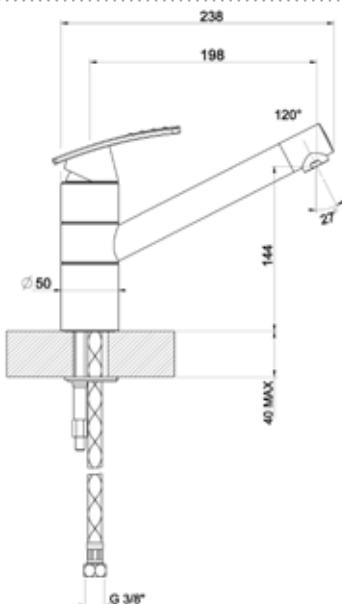



# FABELLA II

## Features:

- Ceramic Disk Cartridge
- Solid Brass Construction
- Chrome Plated
- 5 Year guarantee on body construction
- 2 Year guarantee on ceramic cartridge



Fabella II - Retractable  
**Product Code: 303356**

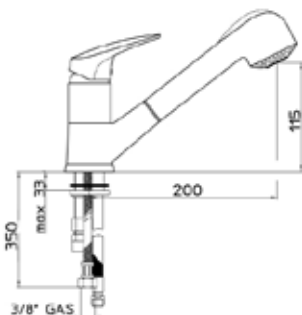

Fabella II - Prep Bowl  
**Product Code: 303354**

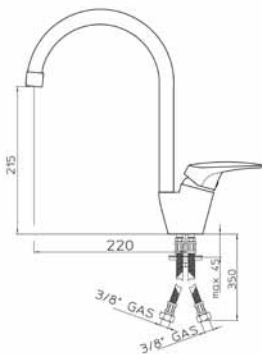

Fabella II - Swivel  
**Product Code: 303352**

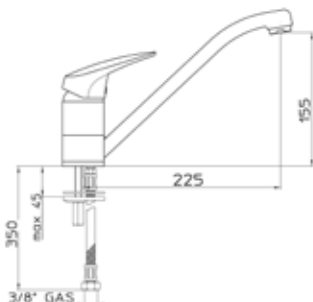



# CASCADE

## Features:

- Ceramic Disk Cartridge
- Solid Brass Construction
- Chrome Plated
- 5 Year guarantee on body construction
- 2 Year guarantee on ceramic cartridge



Cascade Prep Bowl  
Product Code: 303232

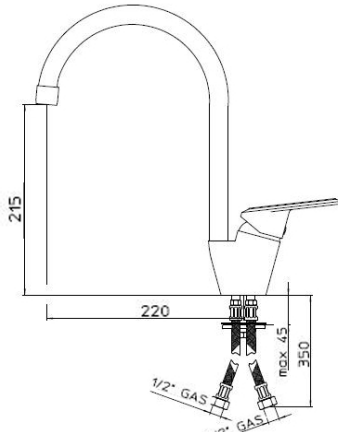

Cascade Swivel  
Product Code: 303355

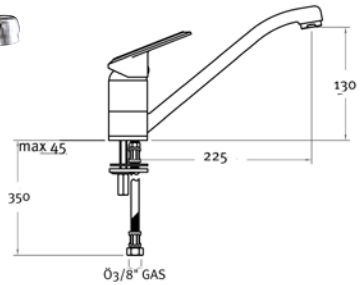

## **FRANKE KITCHEN SYSTEMS (PTY) LTD**

### **CALL CENTRE**

TEL: 0861 372 653

FAX: (+27-31) 450 6302

e-mail: enquiry.fsa@franke.com

Website: www.franke.co.za

### **DURBAN**

1194 South Coast Road,  
Mobeni, Durban, 4092.

South Africa.

TEL: (+27-31) 450 6300

FAX: (+27-31) 450 6303

### **GAUTENG**

77 Roan Crescent,  
Sage Corporate Park North,  
Old Johannesburg Road,  
Midrand, 1682  
South Africa

### **CAPE TOWN**

#### **Sales Office,**

Franke Kitchen Systems  
M5 Business Park  
Unit 14, 2nd Floor,  
Eastman Road, Maitland  
Cape Town, 7405  
South Africa

#### **Showroom,**

M5 Business Park  
Unit 2A, Block A  
Eastman Road, Maitland

**[www.franke.co.za](http://www.franke.co.za)**

### **DISCLAIMER**

The information and data supplied in this brochure is based on information believed to be reliable, however it is not binding and inaccuracies may occur. Franke reserves the right to change specifications and design at any time without notice.

© 2010 by Franke Kitchen Systems (Pty) Ltd. All rights reserved under the Copyright Act of 1987 with amendments. Reproduction of any of the content, full or partial, is allowed only with the prior written approval of Franke Kitchen Systems (Pty) Ltd. No reasonable requests will be refused provided conditions as laid out are met.