

GASMATE

Instantaneous Gas Water Heaters



HEATS WATER

IMMEDIATELY

FORCED AND NATURAL DRAFT GAS WATER HEATERS



GASMATE

Forced Draft Instantaneous Gas Water Heater



20 Litre

product application

Kwikot Gasmate Forced Draft Instantaneous Gas Water Heater 20 litre water heater is suitable for the usage of large volumes of hot water for bathing and showering. The unit is for **outdoor installation only** and operates solely on **LPG Gas**.

product features

Compact and aesthetically appealing, this gas water saves on space when installed outdoors.

Easy to operate as the water heater incorporates a micro-computer which controls the electronic proportional valve, step-less speed changing DC fan and a high loading burning device, resulting in the unit generating hot water automatically when the power is switched on and the tap is opened.

With the built-in micro-computer, the water heater automatically attempts to generate water at the pre-set temperature. In computing the volume of gas and air to heat up the water flowing into the water heater, it takes into consideration the water pressure, the temperature of the water flowing into the water heater and the pre-set temperature of the water flowing out of the water heater.

With the sensitive ultra-low water pressure starting device, the water heater can operate even at low water pressures.

The water heater has one remote controller, which can be installed away from the outside where the water heater is installed. An additional two more remote controllers can be purchased as an optional extra and be installed at other convenient locations.

When the main power switch is first turned on, the LED display will indicate 42°C and after 3 seconds, it will show the actual temperature of the water flowing out of the water heater. The user in the priority mode may then set their preferred temperature for the water outflow. As long as the main power switch is not turned off, the water heater will continue to operate and generate water at the selected pre-set temperature during usage. The display will also flash the fault code accordingly to indicate the nature of the fault of the water heater whenever the heater malfunctions.



Remote Controller (FGI-20L-REM)

technical specification data

	Model	20 litre
<p>559mm</p> <p>378mm</p> <p>146mm</p> <p>Bottom view</p>	Product Code Type of Gas Rated Gas Pressure Input Power Rating Output Power Rating (thermal load) Hot Water Output Capacity Installation Location Heat Efficiency Ignition Mode Lowest Starting Water Pressure Maximum Working Pressure Hot Water Temperature Range Control Mode: Hot Water Temperature Control Mode Delay Ignition Mode Pipe Connection Mode: Water Inlet and Outlet Pipe Gas Inlet Electrical: Voltage Frequency of Power Supply Rated Power Fan Power Supply Cord Length Outer Dimensions (mm) Empty Weight	FGI-I20-LPG Liquid Petroleum Gas (LPG) 0,8kPa / 2kPa 40kW 60kW 20 lts/min (temperature rise: 25°C) Outdoor Only > 88% Hydraulic Type Electric Pulse Ignition 10kPa 800 kPa 35 to 55°C Electronic Proportional Valve + Electronic Fire Section Soft-Start Mode G1/2" G3/4" AC220V / 50Hz 60W DC Motor 1.5m 559 x 378 x 145 16kgs



GASMATE

Natural Draft Instantaneous Gas Water Heaters

product application

The Kwikot Gasmate Natural Gas Instantaneous Gas Water Heaters 5 litre is suitable for the immediate supply of hot water for kitchen sinks and preparation bowls, laundry wash troughs, bathroom wash hand basins and the larger 11 litre and 14 litre models for showers and baths as well.

product features

All models are of a natural flue type, automatic water control operation with a flow stabilizing device, and efficient combusting system with pulse ignition. The battery ignition is by 2 x D Cell Torch Batteries, which provides the power to open the gas solenoid and fire the igniters when the water flow is detected. Once the gas is ignited, the igniters cease firing and the water heats up immediately.



14 Litre

11 Litre

5 Litre

technical specification data

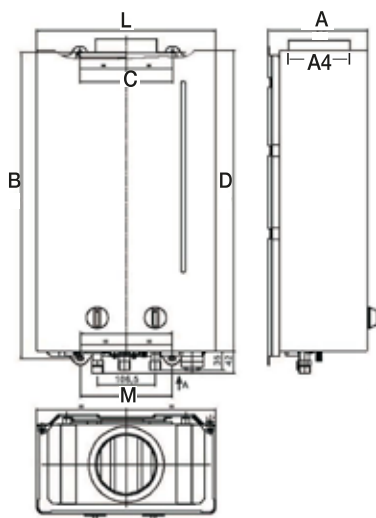

Top view

Capacity (Litres)	A	B	D	C	L	A4	M
5	129	452	450	55	280	Ø80	55
11	181	560	550	170	328	Ø110	170
14	187	660	650	220	400	Ø130	220

(All measurements are in mm)



CE CERTIFICATION 0461BT0927

Model		14 litre	11 litre	5 litre
Product Code (LPG)		FGI-C14-LPG	FGI-C11-LPG	FGI-C5-LPG
Product Code (Natural Gas)		FGI-C14-NG	FGI-C11-NG	FGI-C5-NG
Water Heating Energy Efficiency Class		A	A	A
Water Heating Energy Efficiency (η_{WH})	%	72,1	74,5	87,3
Sound Power Level (L_{WA})	Db	59	58	51
Nox Emissions	mg/kWh	196	227	212
Gas Category		II2H3+	II2H3+	II2H3+
Type of Unit		B11BS	B11BS	B11BS
Type of Installation		Internal	Internal	Internal
Maximum Heat Input	kW	26,8	21,1	10,1
Maximum Heat Output	kW	23,8	18,9	8,9
Pmax Efficiency	%	88,8	89,0	89,0
Burner Injectors G20 (NG number of & size)	n°xΦ	16 x 1.02	10 x 1.15	6 x 1.00
Gas Pressure G20 (NG)	Mbar	20,0	20,0	20,0
Maximum Gas Flow Rate G20 (NG)	m ³ /h	2,83	2,23	1,07
Burner Injectors G31 (LPG number of & size)	n°xΦ	16 x 0.66	10 x 0.72	6 x 0.66
Gas Inlet Pressure G31 (LPG)	Mbar	37,0	37,0	37,0
Maximum Gas Flow Rate G31 (LPG)	Kg/h	2,09	1,65	0,79
Maximum Working Pressure	bar	10	10	10
Minimum Working Pressure Δt 25°C	bar	0,4	0,4	0,4
Minimum Working Pressure Δt 50°C	bar	0,2	0,2	0,2
DHW Flow Rate Δt 25°C	l/min	13,7	10,8	5,1
DHW Flow Rate Δt 50°C	l/min	6,8	5,4	2,6
Power Supply Voltage (2 x 1,5V DC)	V/Hz	3	3	3
Weight Empty	Kg/h	13	9	5







GASMATE

Natural Draft Instantaneous Gas Water Heaters

additional installation components

A selection of Kwikot installation components is available for the 5 litre, 11 litre and 14 litre **Natural Draft Instantaneous Gas Water Heaters**.

Model	Product Code for Complete Kit	Product Code for Individual Kit Components
5 Lt 	FGI-INS-KIT-5 Cowel Fluepipe Wall Bracket Adapter	 <p>Cowel _____ 5 Lt; 11 Lt & 14 Lt FGI-COWEL</p> <p>Fluepipe _____ 5 Lt; 11 Lt & 14 Lt FGI-FLUEPIPE</p> <p>Wall Bracket _____ 5 Lt; 11 Lt & 14 Lt FGI-WALL BRACKET</p> <p>Adapter _____ 5 Lt FGI-ADAPT-5 14 Lt FGI-ADAPT-14</p> <p>Exhaust Outlet</p>
11 Lt 	FGI-INS-KIT-11 Cowel Fluepipe Wall Bracket NB. This unit does not require an adapter as the Fluepipe fits directly onto the exhaust outlet	
14 Lt 	FGI-INS-KIT-14 Cowel Fluepipe Wall Bracket Adapter	

product installation data

All Gas Water Heaters may only be installed by a gas installer registered with the South African Qualifications & Certification Committee (SAQCC) and installed in accordance with the requirements of SANS 10087-1 for the use with LPG gas, SANS 827 for the use with Natural gas and any other fire department regulations and/or local bylaws applicable to the area.

product warranty

The Forced Draft and Natural Draft Instantaneous Gas Water Heaters have a two year warranty period from date of purchase validated by means of a purchase invoice. Alternatively if an invoice cannot be produced, the warranty period will be determined by the manufacture date code on the gas water heaters. **Electrolux SA (Pty) Ltd** makes no warranties or representation in respect of the installation of the gas water heaters.

The warranty is applicable to South Africa, Botswana, Lesotho, Namibia and Swaziland and subject to water conditions equivalent to main Metropolitan supply authorities in South Africa.

Electrolux SA (Pty) Ltd

head office

inland division

3 Aberdeen Road,
Industrial Sites,
Benoni

Tel: (011) 897 4600

AFTER SALES SERVICE TEL:
0861594568

eastern cape division

31-34 Leadwood Crescent,
Fairview,
Port Elizabeth

Tel: (041) 399 4000

Fax: (041) 367 1005

western cape division

15 Purdey Road,
Sheffield Business Park, Phillippi,
Cape Town

Tel: (021) 690 2700

Fax: (021) 690 2800

kwazulu-natal division

814 Peter Close,
Springfield Park,
Durban

Tel: (031) 574 8700

Fax: (031) 574 8750