



COMMERCIAL

stainless steel



HOSPITAL EQUIPMENT baby baths

MODELS BBDI, BBGB & BBL





COMMERCIAL

stainless steel

BABY BATHS MODELS BBDI, BBDG & BBL

features

- Grade 304 (18/10) Stainless Steel 1,2mm gauge
- Semi-circular bowl
- Hygienic and durable
- Recessed drainer to help avoid water spillage



specifications for model BBDI

Kwikot Model BBDI inset Baby Bath, size 915 x 550mm wide manufactured from Grade 304 (18/10) Stainless Steel. The unit is fitted with a semi-circular bowl measuring 690 x 365 x 165mm deep with provision for 40mm round waste outlet. Cut out size is 875 x 515mm.



standard size for model BBDI baby bath

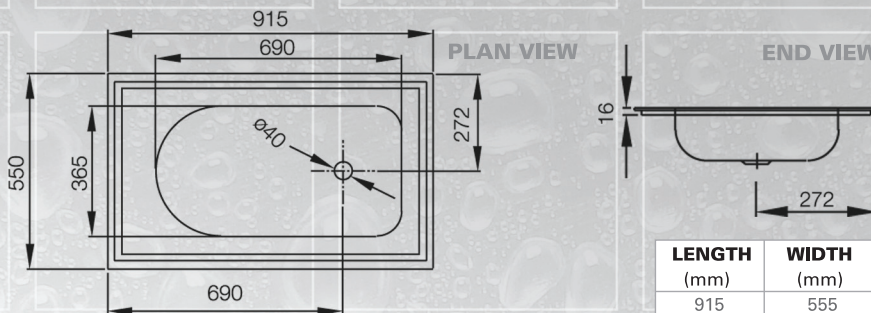

MODEL BBDI

specifications for models BBGB & BBL

Kwikot Model (please specify) Baby Bath, length 1500 x 555mm wide, are manufactured from Grade 304 (18/10) Stainless Steel, with a 150mm integral splashback. The unit is fitted with a semi-circular bowl measuring 690 x 365 x 165mm deep with provision for a 40mm round waste outlet. The underside of the drainer has vermin proof bitumastic sound deadening coating supported with a galvanised backing sheet. Unit mounted onto 41mm ϕ round Stainless Steel legs with adjustable foot pieces (Model BBL) 40 x 40mm Stainless Steel gallows brackets with 41mm ϕ round Stainless Steel front legs and adjustable foot pieces for fixing to wall and floor (Model BBGB).



standard size for models BBGB & BBL baby baths

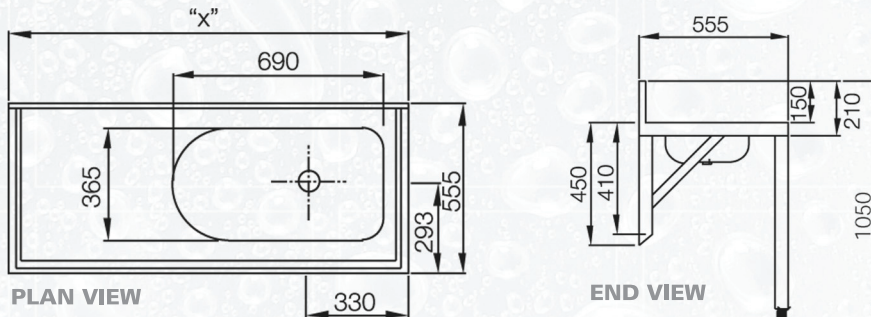

MODEL	LENGTH (mm) x	WIDTH (mm)	FIXING METHOD
BBGB	1500	555	Stainless Steel gallows brackets and front legs
BBL	1500	555	Stainless Steel legs

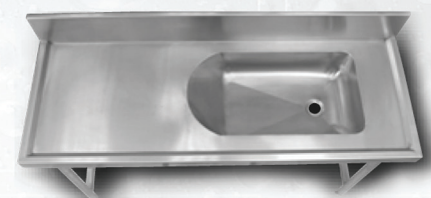

MODEL BBL

Kwikot (Pty) Ltd
Inland Division
 P.O. Box 1016
 Benoni
 1500
 Tel: 011 897 4600
 Fax: 011 914 4750

Kwikot (Pty) Ltd
Kwazulu-Natal Division
 P.O. Box 47366
 Greyville
 Durban
 4023
 Tel: 031 574 8700
 Fax: 031 574 8750

Kwikot (Pty) Ltd
Eastern Cape Division
 P.O. Box 29142
 Sunridge Park
 Port Elizabeth
 6008
 Tel: 041 399 4000
 Fax: 041 367 1005

Kwikot (Pty) Ltd
Western Cape Division
 P.O. Box 32072
 Ottery
 Cape Town
 7808
 Tel: 021 690 2700
 Fax: 021 690 2800

After Sales Service :
0861KWIKOT (594568)

www.kwikot.com