



COMMERCIAL

stainless steel



**HOSPITAL
EQUIPMENT**
slop hopper MODEL KSH
MODEL KDSG **drip sink**



HOSPITAL EQUIPMENT - SLOP HOPPER & DRIP SINK



COMMERCIAL stainless steel



SLOP HOPPER MODEL KSH GRID

features

- Grade 304 (18/10) Stainless Steel
- 1,2mm gauge
- Hygienic and durable
- Stainless Steel hinged bucket grid
- Outlet to suit standard 110mm PVC or cast iron "P" trap

specifications for KSH slop hopper

Kwikot Model KSH slop hopper with Stainless Steel grid size 540 x 540mm with a 100mm high integral splashback to back and both ends with an integral flushing rim fitted with a 38mm ϕ x 250mm long vertical flush pipe inlet. A hinged bucket grid fitted over funnel, manufactured from 10mm round Grade 304 (18/10) Stainless Steel round bar. Unit fitted on 40 x 20mm square Stainless Steel wall fixing brackets having two number 8mm round holes for fixing to wall. Standard flushing methods:-

- Cobra model FM1.000 35mm round water supply flush valve or
- Cobra model FJ2.000 20mm round water supply flush valve, and Cobra FJ1.2 straight flush pipe connected to CP on brass adaptor. Flush valve elsewhere measured.

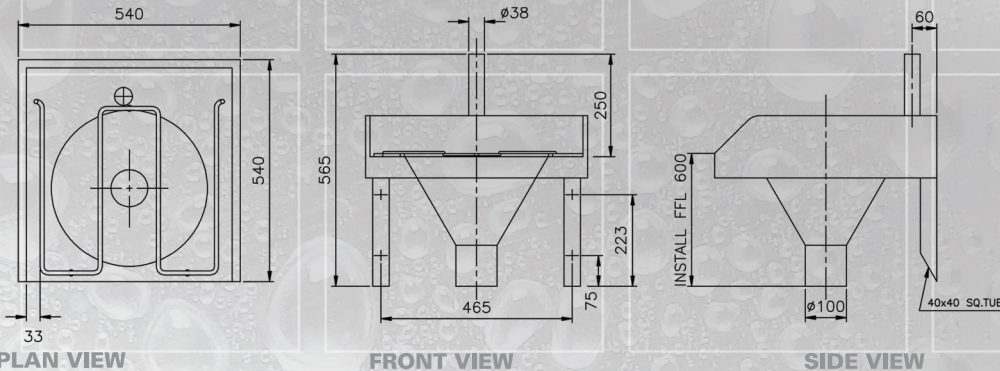

MODEL KSH



alternative flushing using high level cistern

Slop hopper can be adapted to flush using an eleven litre high level cistern (optional extra).

specification for high level cistern

Grade 304 (18/10) Stainless Steel high level cistern fitted with PVC flushing mechanism and pull chain connected to unit with 41mm round Stainless Steel flushpipe and CP on brass adaptor.



CISTERN

DRIP SINK MODEL KDSG

features

- Grade 304 (18/10) Stainless Steel 1,2mm gauge
- Hygienic and durable
- Pressed Bowl
- Stainless Steel hinged bucket grid
- Stainless Steel wall mounted brackets

specifications for KSDG drip sink

Kwikot Model KDSG drip sink 530 x 490 x 290mm deep, manufactured from Grade 304 (18/10) Stainless Steel hinged bucket grid with 100mm integral splashback to back. Unit fitted with 40 x 40mm square Stainless Steel wall brackets and provision for 90mm waste outlet (90mm basket waste fitting included). Unit to be fitted 600mm from finished floor level.

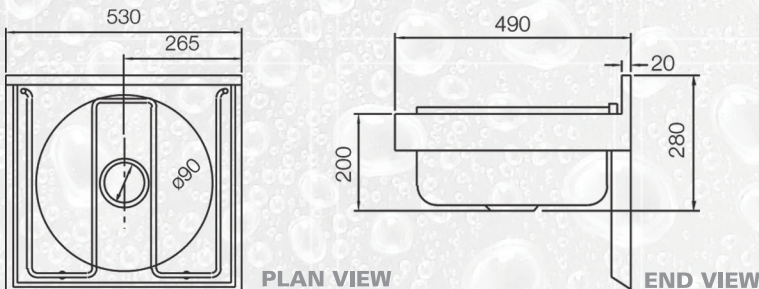

MODEL KDSG



**Kwikot (Pty) Ltd
Inland Division**
P.O. Box 1016
Benoni
1500
Tel: 011 897 4600
Fax: 011 914 4750

**Kwikot (Pty) Ltd
Kwazulu-Natal Division**
P.O. Box 47366
Greyville
Durban
4023
Tel: 031 574 8700
Fax: 031 574 8750

**Kwikot (Pty) Ltd
Eastern Cape Division**
P.O. Box 29142
Sunridge Park
Port Elizabeth
6008
Tel: 041 399 4000
Fax: 041 367 1005

**Kwikot (Pty) Ltd
Western Cape Division**
P.O. Box 32072
Ottery
Cape Town
7808
Tel: 021 690 2700
Fax: 021 690 2800

After Sales Service :
0861KWIKOT (594568)

www.kwikot.com