

# Kwiksol

SOLAR WATER HEATING

**INDIRECT**

SYSTEM FOR FROST LOCATIONS



EFFICIENT USE OF NATURAL  
SOLAR ENERGY FROM THE

# SUN

DOMESTIC SOLAR WATER HEATERS WITH SOLAR COLLECTOR PANELS & SOLAR VACUUM TUBES



## Solar Water Heaters - Close Coupled & Split - Indirect System

### indirect system

The indirect system is used in locations where frost occurs, where the ambient temperature falls below 5°C and where the water quality is poor (more than 600ppm Total Dissolved Solids / Minerals). The system can be used with one or two Solar Collector Panels dependent on the capacity of the solar tank.

An indirect system is where the potable water used in the household (hot water) does not circulate through the solar collector panels, but remains in the solar water heater and is heated through a heat exchanger around the vessel. Propylene glycol is circulated through the solar collector panels, transferring solar energy into the heat exchanger and in turn heating the water in the solar water heater.

The potable water and propylene glycol never mix and are held in separate chambers within the solar water heater. The tank and solar collector panels are connected together with two copper tubes, which are used to transfer heated propylene glycol from the solar collector panels to the storage tank heat exchanger. Propylene glycol does not freeze and therefore protects the solar collector panels from freezing damage in frost prone areas.

The indirect system can be installed as a Split System (pumped or thermosyphon circulation methods), where the solar water heater is installed inside the roof or away from the solar collector panels, or installed as a Close Coupled System (thermosyphon circulation), where the solar water heater is installed outside on the roof and above or higher than the solar collector panels (See section Circulation Methods).

**Potable water alone must never be used as the heat transfer fluid in a Kwikot Kwiksol Solar Water Heater Indirect System and only Propylene Glycol diluted with potable water must be used.**

### solar water heater product features

- The Kwikot Kwiksol Solar Water Heater Indirect System complies with SANS 1307, is SABS **400kPa** approved and can be used as a close coupled system or split system.
- The inner cylinder is manufactured from 2mm steel and thermo fused porcelain enamelled for cylinder longevity and hygiene.
- Polyurethane insulation between the heat exchanger and outer casing reduces energy and heat loss.
- 2 x aluminium sacrificial anodes are fitted for corrosion protection.
- The solar water heater is designed for domestic hot water application in conjunction with one or more solar collector panels or solar vacuum tubes. The Solar Water Heater is fitted with an Isolator Switch (IPX4 rated).
- The two extra fluid connections required for connecting solar collector panels or solar vacuum tubes, and the booster element ensures that the solar water heater can be used as a conventional electric water heater and as a solar water heater.
- The solar water heater thermostat will automatically switch on when the incoming hot propylene glycol fluid from the solar collector panels has not reached the set temperature setting on the thermostat. This will occur on cloudy days and at night when the water temperature drops in the solar water heater or when hot water is drawn off and cold water enters the solar water heater.

### solar water heater product specification data

Capacity (Litres)	Element Rating (Kw)	Operating Pressure (kPa)	Mass Empty (kg)	Water Connections (BSP Male)	Solar Connections (BSP Male)
150	2	Up to 400	48	¾"	¾"
200	2	Up to 400	62	¾"	¾"
300	2	Up to 400	98	¾"	¾"

Product Code	Capacity (Litres)	Dimension A (mm)	Dimension B (mm)
SOL - 150 - IND	150	1035	600
SOL - 200 - IND	200	1325	600
SOL - 300 - IND	300	1935	600

  

**NB. 150lt and 200lt: Galvanised Outer Casing**  
**300lt: Stainless Steel Outer Casing**

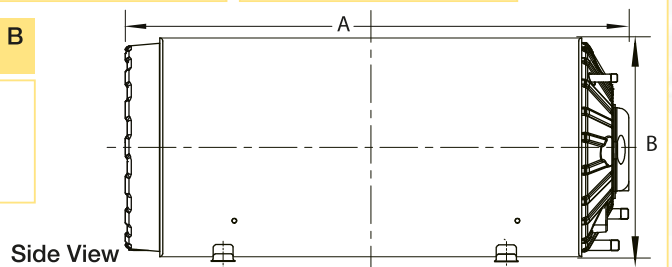

### product installation data

- Where the solar water heater is installed in the roof, it must be installed in compliance with SANS 10106 Solar Water Heater and SANS 10254 Specification complete with a Temperature & Pressure Valve (Safety Valve), Drain Cock, Expansion Relief Valve 100kPa (all supplied with the solar water heater), Multi Pressure Control Valve Vacuum Breakers on the cold water supply and hot water supply.
- Geyser feet can be moved from a horizontal angle to a 30° angle.

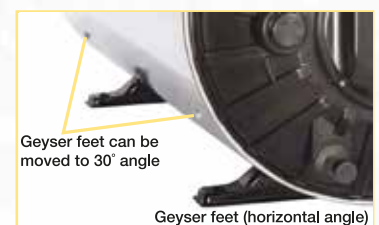

- The 15mm (½") Expansion Relief Valve 100kPa is to be fitted to the jacket on the solar waterheater to allow for any expansion during the heating process.
- If the solar water heater is installed in the roof, the following minimum installation clearance must be allowed for on each side of the solar water heater in order to remove the element or thermostat and the anode/s from the opposite end:  
150lt – 450mm  
200lt/300lt – 920mm
- If the solar water heater is installed in the roof, the following minimum installation clearance must be allowed for on each side of the solar water heater in order to remove the element or thermostat and the anode/s from the opposite end:  
150lt – 450mm  
200lt/300lt – 920mm
- If the solar water heater is installed on the roof, careful inspection must be carried out to ensure that the roof can support the weight of the entire installation system once it is filled with water. Care must be taken where the front feet of the solar water heater are located. The feet should be located over a tile batten, purlin or similar for maximum strength.

## product warranty and anode servicing

The period of warranty is from the date of installation providing that documented proof of the installation is furnished, or alternatively from date of manufacture as determined from the serial plate code on the solar water heater.

- One year on the heating element, thermostat, flange assembly plate and gasket.
- Two years on the Safety Valve, Drain Cock and Expansion Relief Valve.
- Five Years on the inner cylinder, subject to water conditions equivalent to main Metropolitan supply authorities. This warranty is subject to only genuine Kwikot replacement parts (heating element and thermostat etc) being used whilst the inner cylinder is still under guarantee.
- The warranty on the installation is the responsibility of the installer.

Water specification and Anode servicing/replacement is as follows:



Total Dissolved Solids (Parts per Million)	Recommended Anode Replacement
100-600	3 Years
601-1000	2 Years
Over 1000	1 Year

## Solar Collector Panels

### solar collector panel product features

- Manufactured with an Aluminium frame, 4mm toughened prismatic, non-reflective anti-hail tempered glass.
- Durable copper waterway tubes.
- Rubber seals ensure durability and reliability in extreme climatic conditions.
- Semi-selective black chrome surface on copper substrate offers maximum absorption efficiency.
- Total and useful energy rating 4.19kWh/m<sup>2</sup>

Product Code	Dimensions (mm)	Aperture Area (m <sup>2</sup> )	Mass Empty (kg)	Mass Full (kg)	Energy Transfer Fluid
SOL - PANEL - 2B	2000 x 1000 x 80	2.0	30	32	Propylene Glycol
SOL - PANEL - 2.5	2000 x 1250 x 80	2.5	40	46	Propylene Glycol

Solar Water Heater Capacity (lts)	Number of Solar Collector Panels (m <sup>2</sup> )
150	1 x 2m <sup>2</sup> Panel
200	1 x 2.5m <sup>2</sup> Panel
300	2 X 2m <sup>2</sup> Panels

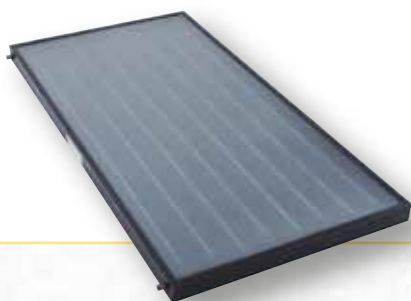

## product installation data

### Roof Location and Pitch

- For optimum performance the solar collector panels need to face the equator (facing north for southern hemisphere installations). Installation on angles of up to 45° away from the equator do not have a major effect on the annual solar output, consequently roof locations which face less than 45° away from the equator are acceptable. Solar irradiance from the sun begins at about 10:00 until about 16:00 and at its peak between 12:00 and 14:00

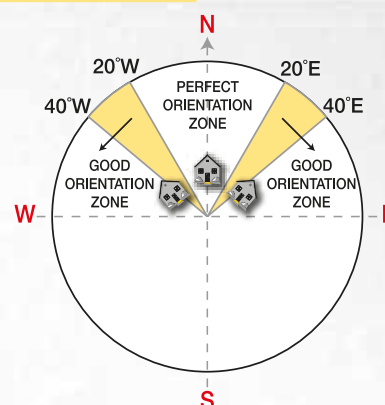

- If the solar collector panels are installed with an east facing bias, the best solar capture is best achieved in the morning, and if installed with west facing biased, in the afternoon.
- The location should not be subject to excessive shading from trees and adjacent buildings and particularly between 9am and 15:00. Remember that shadows are longer in winter than in summer so a location that is free of shadows in summer may have some shadows in winter.
- The solar collector panels should be installed on a roof pitch greater than 8° and less than 30°. Where the roof pitch is greater than 30°, the installation will require additional support to prevent it from moving downwards when installing and after installing. If the solar water heater is mounted on the roof above the solar collector panels, additional support for the solar collector panels can be made at the solar water heater. If the roof pitch is less than 8°, the installation will require a mounting frame to increase the pitch to above 8°.

**Installations below 8° do not thermosyphon effectively and the solar collector panel glass will not clean properly when it rains.**

- If the solar water heater is installed on the roof, careful inspection must be carried out to ensure that the roof can support the weight of the entire installation system once it is filled with water.

## **product warranty**

The solar collector panel has a comprehensive 5 year warranty from date of installation and subject to the following conditions:

- The warranty only applies to defects, which have arisen solely due to faulty materials and workmanship during the manufacturing process of the solar collector panel.
- If any component fails during the warranty period, Kwikot will replace or repair the failed component free of charge.
- Any damage caused to the solar collector panel due to propylene glycol not being used in an indirect system, is not covered by the warranty.
- The solar collector glass is not covered by the warranty.
- The warranty on the installation is the responsibility of the installer.

## **circulation methods**

**Only use Propylene Glycol Heat Transfer Fluid in both circulation methods.**

### 1. Pump Circulation in a Split System

- It is not always possible or convenient to place the solar water heater in a higher position than the solar collector panels. A circulating pump, controlled by an electronic control unit, therefore becomes necessary. The control unit using two sensors constantly monitors the temperature of the solar collector panels, powering the circulation pump only when the propylene glycol transfer fluid in the solar collector panels is hotter than the water in the solar water heater.
- When the temperature difference is less than the set point during the working process of the circulating pump, the pump will stop.
- When the temperature of the water in the solar water heater reaches the highest set point, the controller will stop the circulating pump.
- The electrical thermostat and element will automatically maintain the water temperature of the upper part of the solar water heater.
- The set temperature on the thermostat must be lower than the maximum temperature attainable on the solar collector panels.
- The circulating pump must be installed in accordance with the manufacturers instructions and ease of access for maintenance/repair.
- A 12V solar circulating pump can also be used, powered by a 12V photovoltaic collector panel and can operate with or without a differential controller.
- Split systems can also be installed as thermosyphon systems, if there is sufficient roof space to locate the solar water heater above the solar collector panels (see installation diagram on back page).

### 2. Thermosyphon Circulation in a Close Coupled and Split System

- The compulsory requirement for a thermosyphon system is that the solar water heater is placed in a position higher than the solar collector panels and circulation occurs without any moving parts or auxiliary electrical energy input to the system.
- This system operates according to a basic principle of physics: a liquid, if heated, becomes less dense and rises upwards.
- Heated water in the solar collector panels rises up into the solar water heater and displaces cold water, which travels back down to the solar collector panels.
- When there is no solar radiation, the water in the solar collector panels, which becomes heavy, blocks the circulation and prevents the heat accumulated in the solar water heater from being dispersed.

**Indirect Thermosyphon  
Close Coupled System  
Installation Diagram**

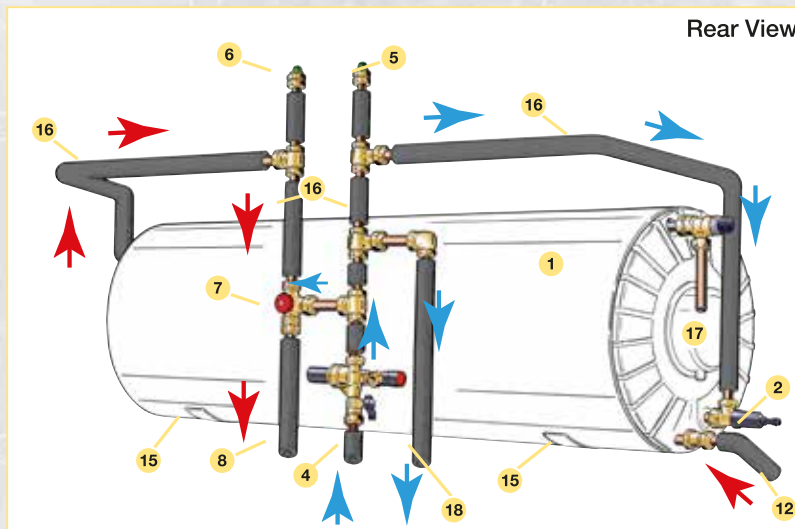
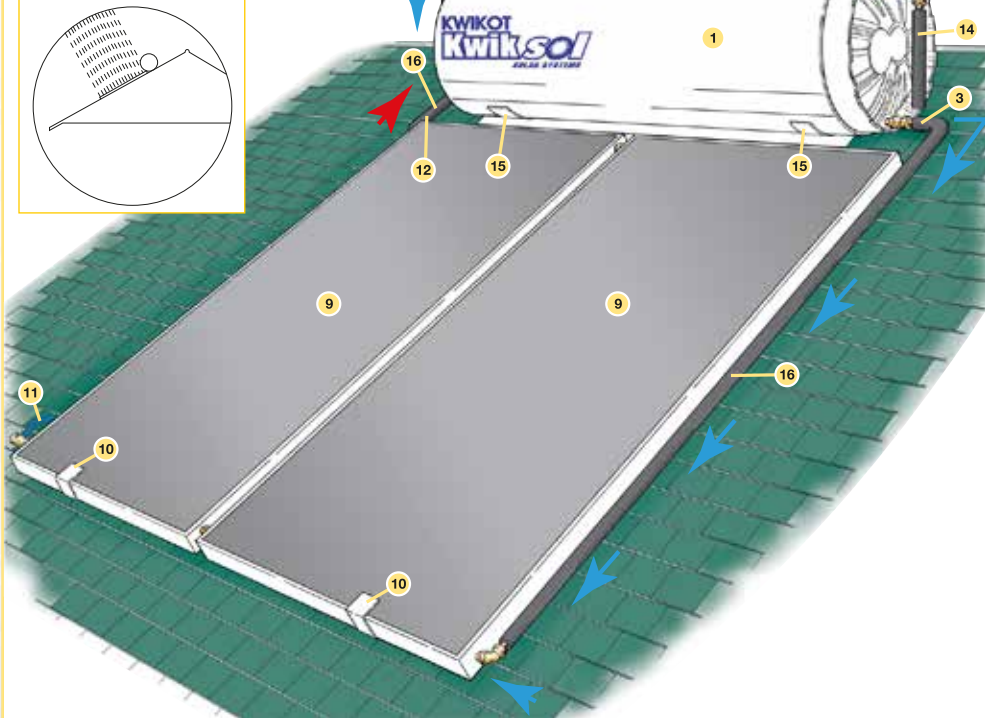

**Indirect Thermosyphon Split System  
Installation Diagram**

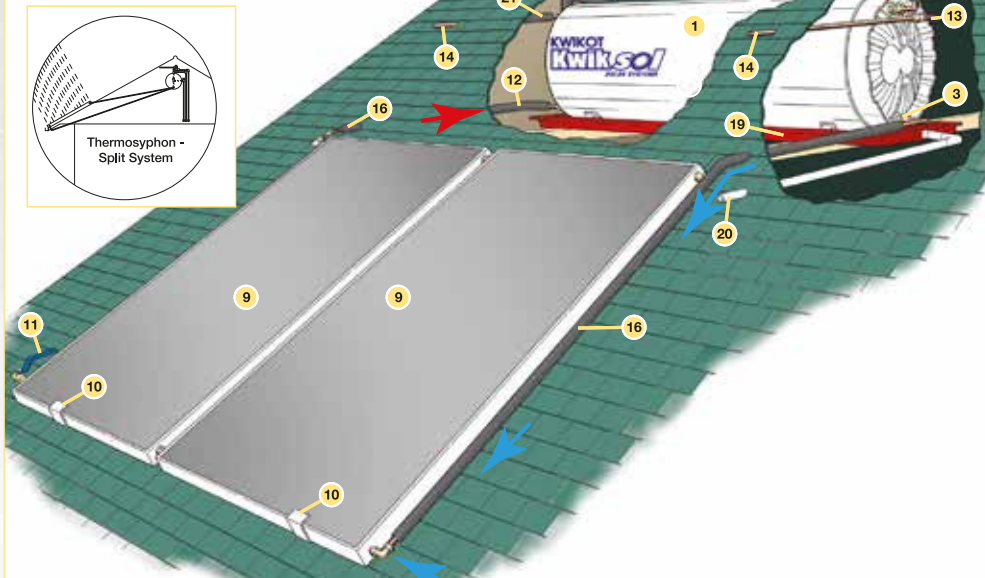

Product Description	
1	Solar Water Heater Indirect, 400kPa
2	Drain Cock
3	Cold Water Feed to Solar Collector Panels
4	Multi Pressure Control Valve, 400kPa
5	Vacuum Breaker Cold Side
6	Vacuum Breaker Hot Side
7	Thermostatic Mixing Valve
8	Hot Water Feed to Taps (Balanced Pressure)
9	Solar Collector Panels
10	Roof Mounting Brackets for Solar Collector Panel
11	Lever Ball Valve
12	Hot Water Feed to Solar Water Heater
13	Safety Valve, 400kPa
14	Expansion Overflow Pipe
15	Pitch Roof Support for Solar Water Heater
16	Thermal Pipe Lagging (R1 Rating)
17	Electrical Cover Plate with Isolator Switch (IPX4 rated)
18	Cold Water Feed to Taps (Balanced Pressure)
19	Drip Tray
20	50mm Overflow from Drip Tray
21	Expansion Valve 100kPa

# solar installation components & accessories

Product Code	Description
	<b>Mounting Brackets &amp; Supports</b>
SOL-BRCT-RM	1. Roof Mounting Bracket for Solar Collector Panel (all sizes)
SOL-BRCT-150	2. Pitch Roof Support for 150lt Solar Water Heater and Panel
SOL-BRCT-200	Pitch Roof Support for 200lt Solar Water Heater and Panel
SOL-BRCT-300	Pitch Roof Support for 300lt Solar Water Heater and Panels
	<b>Frames</b>
SOL-FRM-150	Flat Roof Frame for 150lt Solar Water Heater and Panel
SOL-FRM-200	Flat Roof Frame for 200lt Solar Water Heater and Panels
SOL-FRM-300	Flat Roof Frame for 300lt Solar Water Heater and Panels
	<b>Air Release Valves</b>
KH4.510	Auto Vent Valve (UV Resistant)
	<b>Vacuum Breakers</b>
KHN4.150CX	Kwikot Vacuum Breakers 15mm
KHN4.200CX	Kwikot Vacuum Breakers 22mm
	<b>Circulating Pumps &amp; Solar Photovoltaic Panel</b>
SOL-PUMP-12V	1. Solar Circulating Plastic Pump 12V
SOL-PANEL-12	2. Solar Crystallite Panel 10 Watt
IND-CPN-25-4-BR	3. Electrical Circulating Pump 220V
	<b>Controllers and Timers</b>
SOL-TIMER-1	1. Programmable Geyser Timer Switch
SOL-CTR-2	2. Solar Control AX for Electrical Circulating Pump
SOL-CTR-4	3. Solar Control BS/3 for Electrical Circulating Pump
	<b>Thermal Pipe Lagging (Insulation)</b>
SOL-LAG-15R1	1. High Temperature Lagging 16mm x 1.8m (R1 Rating) 16mm inner Ø & 25mm outer Ø
SOL-LAG-22R1	2. High Temperature Lagging 22mm x 1.8m (R1 Rating) 22mm inner Ø & 25mm outer Ø
SOL-PG-1	Propylene Glycol 1 litre



## kwikot branch and website addresses:

### kwikot (pty) ltd inland division

PO Box 1016, Benoni, 1500  
Tel: (011) 897 4600

**Domestic Sales**  
email: sales.inland@kwikot.com  
**AFTER SALES SERVICE TEL:**  
0861 KWIKOT (594568)

**Export Sales:**  
email: sales.export@kwikot.com

**Information:**  
email: solar.info@kwikot.com

**Technical:**  
email: technical.info@kwikot.com

### kwikot (pty) ltd eastern cape division

PO Box 29142, Sunridge Park, Port Elizabeth, 6008  
Tel: (041) 399 4000  
Fax: (041) 367 1005

**Domestic Sales**  
Email: sales.easterncape@kwikot.com

### kwikot (pty) ltd western cape division

PO Box 32072, Ottery, Cape Town, 7808  
Tel: (021) 690 2700  
Fax: (021) 690 2800

**Domestic Sales**  
Email: sales.westerncape@kwikot.com

### kwikot (pty) ltd kwazulu-natal division

PO Box 47366, Greyville, Durban, 4023  
Tel: (031) 574 8700  
Fax: (031) 574 8750

**Domestic Sales**  
email: sales.kwazulunatal@kwikot.com