

megaflo 450 litre

electric water heaters



450 LITRE
VERTICAL

450 LITRE
HORIZONTAL



FOR AN

AMPLE

SUPPLY OF HOT WATER

LIGHT COMMERCIAL ELECTRIC WATER HEATERS

product features

- Megafile 450 litre electric water heaters have been designed for light commercial and large domestic hot water applications.
- When used with good mains pressure, the water heater can be installed almost anywhere - floor standing or roof.
- Megafile 450 litre water heaters have a polyurethane foam insulation and are finished with a galvanised outer casement.
- The element load cannot be switched directly through the thermostat and a contactor switch rated 30Amp AC1 duty must be utilised. The contactor switch is not a standard component and must be specified and purchased separately.
- Megafile 450 litre can be installed in all areas. For aggressive water conditions, "incolloy" electric heating elements can be requested at an additional cost.
- Megafile 450 litre water heaters operate up to **400kPa** and will work efficiently under lower pressures.

product specification data

- Complies to SABS 151-1992 Specification.

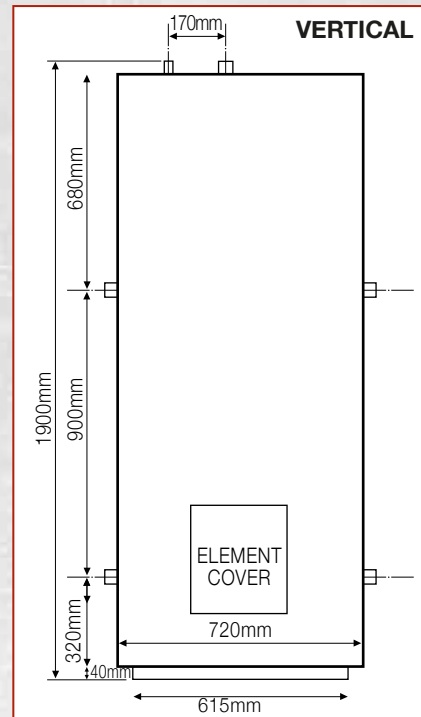
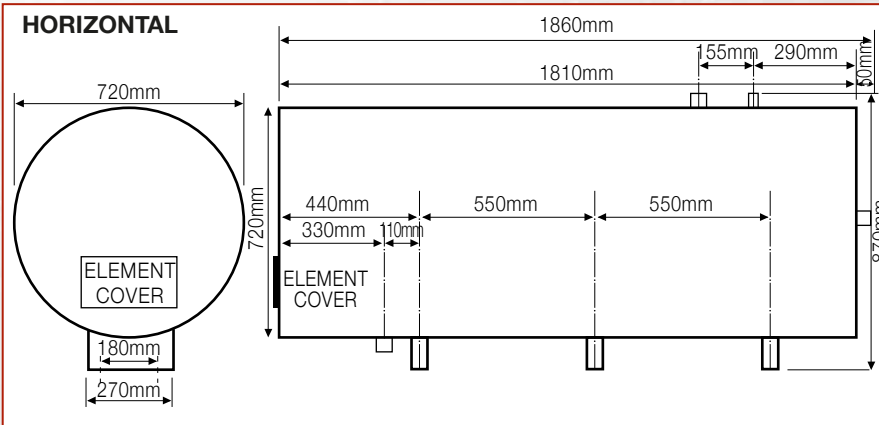

Product Code	Capacity (Litres)	Element Rating (Kw)	Operating Pressure (kPa)	Mass Empty (kg)	Connections (mm) (male iron)
MF 450V (vertical)	450	18	Up to 400	124	40
MF 450H (horizontal)	450	12	Up to 400	129	40

pipng and component installation

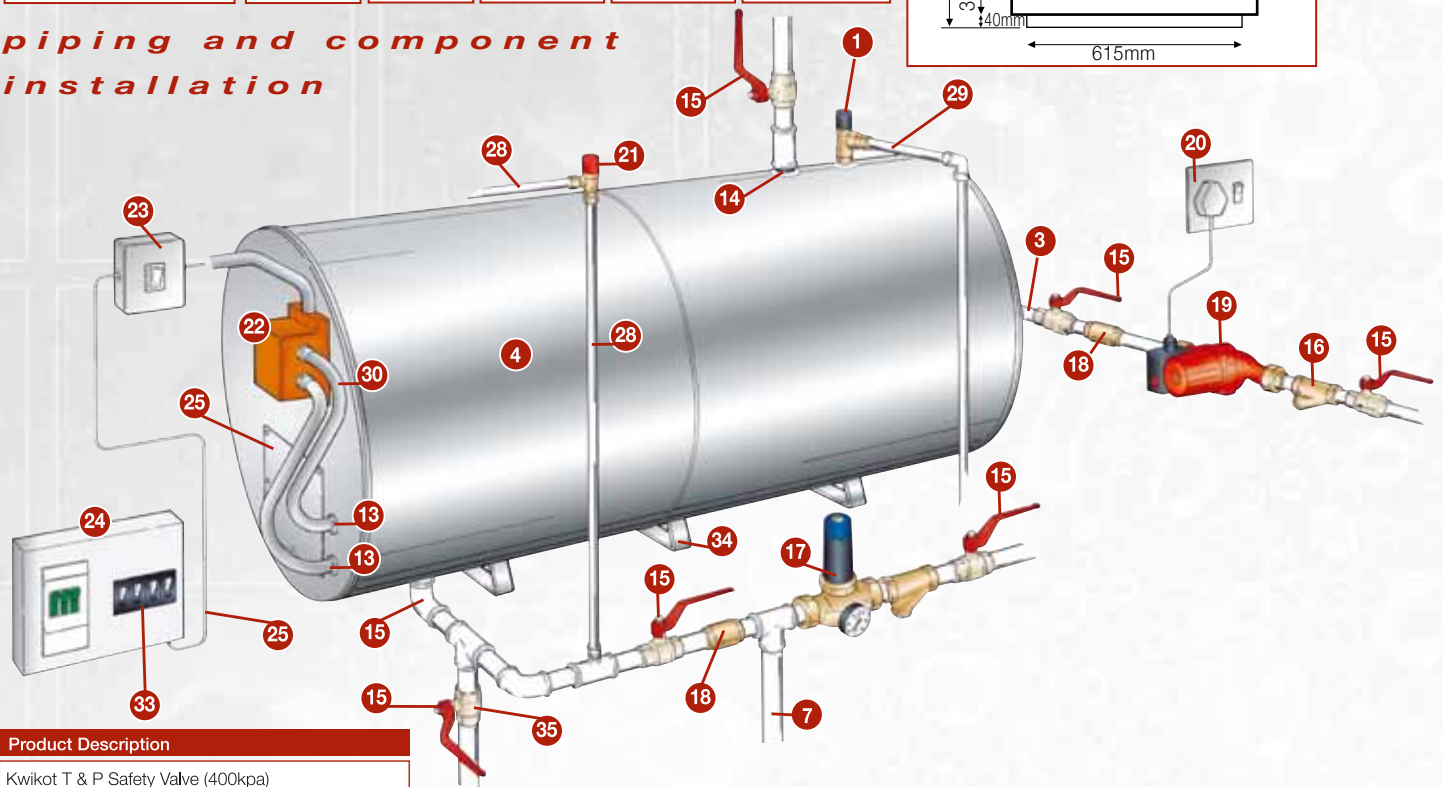

Product Description

1	Kwikot T & P Safety Valve (400kpa)
2	4 X Sacrificial Anodes
3	40mm Return Connection
4	0,8mm Galvanised Sheet Steel
5	Cold Water Inlet
6	Floor Standing Base Ring For Vertical Only
7	Balanced Cold Water Draw Off To Other Services
8	6 X 3kw Standard Immersion Elements (vertical Only)
9	Kwikot VKF 7" Thermostat Set At 60° C
10	Kwikot Thermostat Pocket
11	Thermofused Porcelain Coating
12	50mm Polyurethane Foam Insulation
13	25mm Electrical Conduit Entry

14	40mm Hot Water Outlet
15	Kwikot Isolating Lever-Ball Valve
16	Kwikot Strainer
17	Kwikot Pressure Reducing Valve With or Without Gauge
18	Kwikot Non-return Valve
19	Kwikot Inline Circulation Pump
20	15 Amp Wall Socket
21	Kwikot 400kpa Expansion Relief Valve
22	Contactor Switch
23	3 Phase Isolator
24	Distribution Board (3 Phase)

25	Supply Cable
26	Thermostat Control Wires
27	Electrical Cover Plate
28	Expansion Overflow Pipe (metallic)
29	Safety Overflow Pipe (metallic)
30	Flexible Conduit
31	Terminal Block
32	Earth Stud
33	3-phase Circuit Breaker
34	Kwikot Floor Bracket For Horizontal Cylinder
35	Drain Connection

product installation data

- The water heater must be installed under cover (inside or outside) and not exposed directly to climatic weather conditions.
- The following minimum installation clearance must be allowed for: 500mm clear space around the Safety Valve and for servicing the anodes.
- 300mm clear space immediately in front of the electrical cover plate.
- Do not wall mount.

product warranty and anode servicing

The period of guarantee is from the date of installation providing that documentation of proof of installation is furnished, or alternatively from date of manufacture as determined from the serial plate or date stamp code.

- One year on the standard immersion VKF7" elements, thermostat and flange assembly plate and gasket.
- Two years on the Safety Valve.
- Three Years on the inner cylinder, subject to water conditions equivalent to main Metropolitan supply authorities. This guarantee is subject to only genuine Kwikot replacement parts (element and thermostat etc) been used whilst the inner cylinder is still under guarantee.
- The guarantee on the installation is the responsibility of the installer. Water specification and Anode servicing/replacement is as follows:

Total Dissolved Solids (Parts per Million)	Recommended Anode Replacement
100-600	3 Years
601-1000	2 Years
Over 1000	1 Year

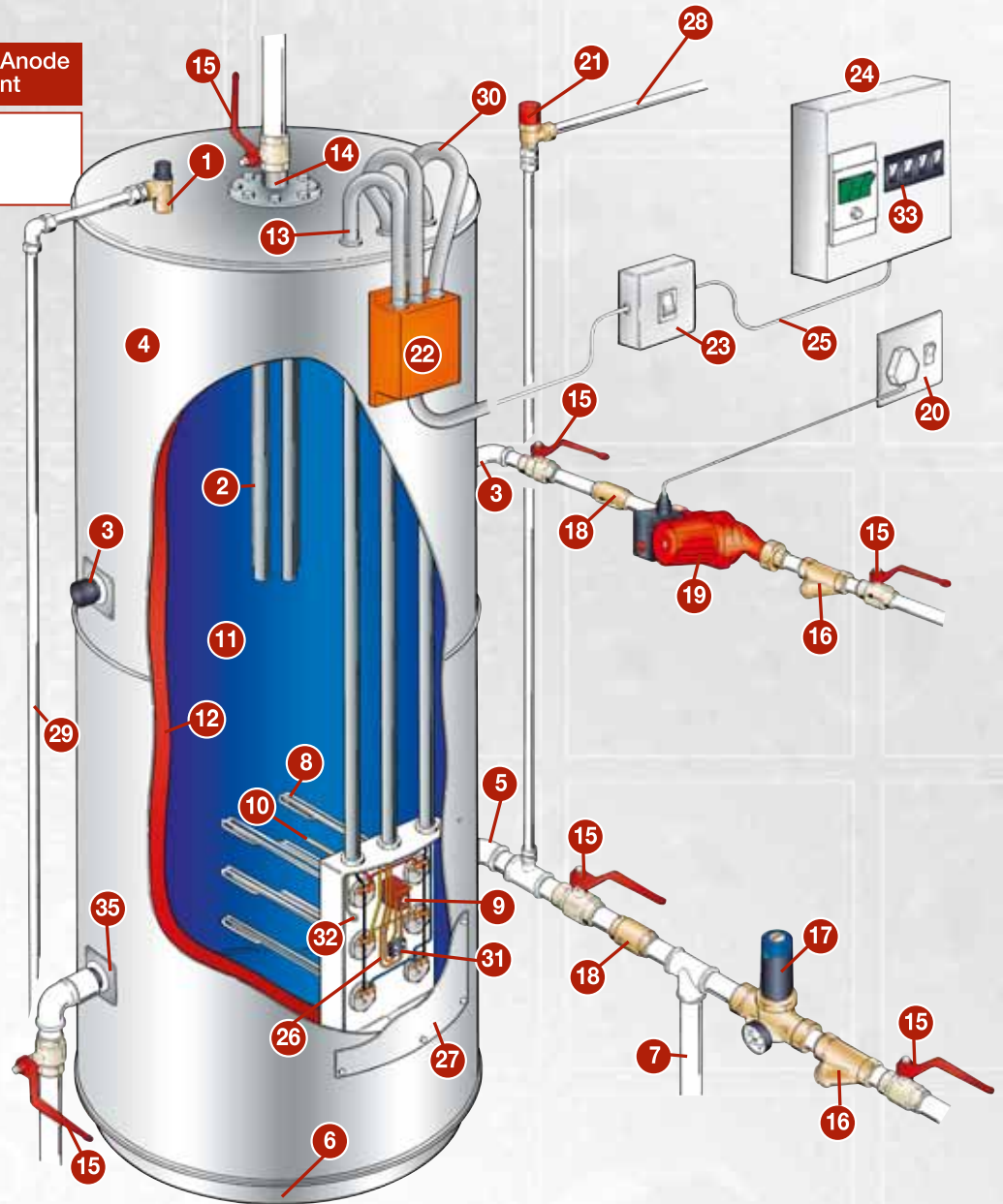

Product Description

1	Kwikot T & P Safety Valve (400kpa)
2	4 X Sacrificial Anodes
3	40mm Return Connection
4	0,8mm Galvanised Sheet Steel
7	Balanced Cold Water Draw Off To Other Services
8	6 X 3kw Standard Immersion Elements (vertical Only)
11	Thermofused Porcelain Coating
12	50mm Polyurethane Foam Insulation
13	25mm Electrical Conduit Entry

14	40mm Hot Water Outlet
15	Kwikot Isolating Lever-Ball Valve
16	Kwikot Strainer
17	Kwikot Pressure Reducing Valve With or Without Gauge
18	Kwikot Non-return Valve
19	Kwikot Inline Circulation Pump
20	15 Amp Wall Socket
21	Kwikot 400kpa Expansion Relief Valve
22	Contactor Switch
23	3 Phase Isolator
24	Distribution Board (3 Phase)

25	Supply Cable
26	Thermostat Control Wires
27	Electrical Cover Plate
28	Expansion Overflow Pipe (metallic)
29	Safety Overflow Pipe (metallic)
30	Flexible Conduit
31	Terminal Block
32	Earth Stud
33	3-phase Circuit Breaker
34	Kwikot Floor Bracket For Horizontal Cylinder
35	Drain Connection



standard fitted accessories

- Immersion elements.
- Fail-safe thermostat graduated between 30°C and 70°C.
- Flange plate with magnesium sacrificial anodes.
- Thermostat pocket.
- The safety valve (supplied fitted to water heater) is designed to release water if the pressure in the water heater approaches **400kPa** or if the temperature approaches 94°C. The safety valve is fitted with a 20mm male thread connection and the overflow is a 22mm Conex, which must be piped with a metallic overflow pipe to the exterior of the building.

additional installation components

A selection of Kwikot installation components available.



Non Return Valves-
15mm to 100mm



Lever Ball Valves-
15mm to 100mm



Screwed-End Circulating
Pumps-
various sizes available



Kwikot Pressure Reducing
Valves-
15mm to 100mm
(150kPa to 600kPa)



electrical wiring diagrams

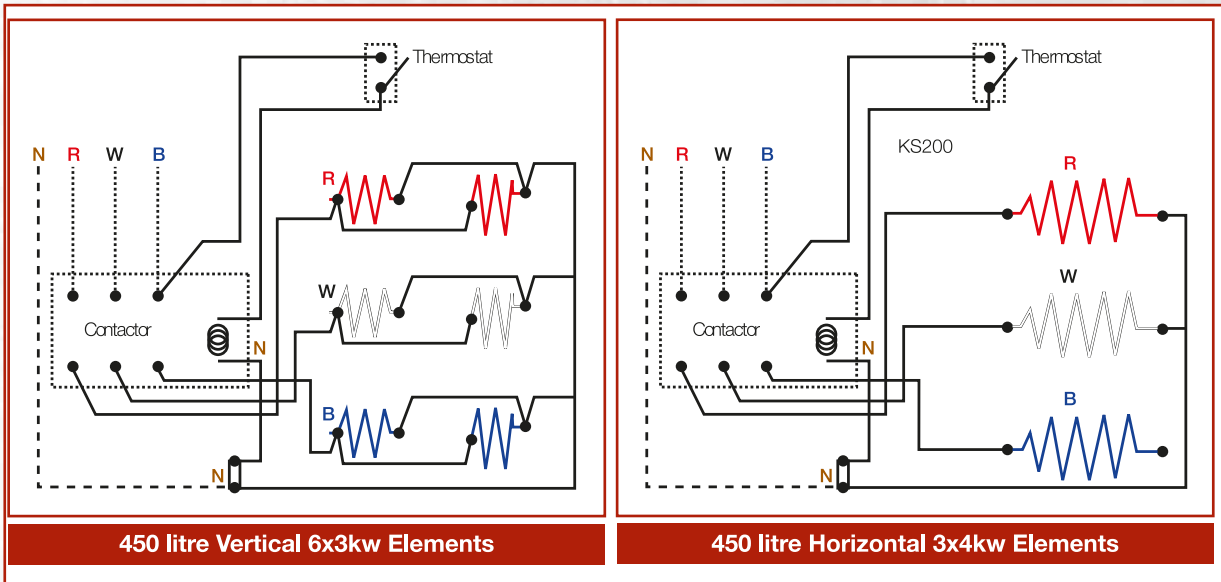

kwikot branch and website addresses:

**kwikot (pty) ltd
inland division**

PO Box 1016 Benoni 1500
Tel: (011) 897 4600
Fax: (011) 914 4750

Domestic Sales
email: sales.inland@kwikot.com
AFTER SALES SERVICE TEL:
0861 KWIKOT (594568)

Export Sales:
email: sales.export@kwikot.com

Marketing:
email: marketing.info@kwikot.com

Technical:
email: technical.info@kwikot.com

Kwikot, first in mind, first in absolute peace of mind

**kwikot (pty) ltd
eastern cape division**

PO Box 29142, Sunridge Park, Port Elizabeth, 6008
Tel: (041) 399 4000
Fax: (041) 367 1005

Domestic Sales
Email: sales.easterncape@kwikot.com

**kwikot (pty) ltd
western cape division**

PO Box 443, Eppindust, 7475
Tel: (021) 690 2700
Fax: (021) 690 2800

Domestic Sales
Email: sales.westerncape@kwikot.com

**kwikot (pty) ltd
kwazulu-natal division**

P O Box 47366, Greyville, 4023
Tel: (031) 574 8700
Fax: (031) 574 8750

Domestic Sales
email: sales.kwazulunatal@kwikot.com

www.kwikot.com