

prisma

Classique



*Point of Use Electric Water Heaters with
Glasslined Inner Cylinder*



SAVES ON WATER
WASTAGE

POINT OF USE ELECTRIC WATER HEATERS



Point of Use Electric Water Heaters with Glasslined Inner Cylinder

product applications

Kwikot Prisma Classique Electric Water Storage Heaters are suitable for domestic kitchens and laundries, medical suites, clinics and office kitchenettes where hot water is readily required. The units solve the problem of having to wait for hot water from larger electric water heaters (geysers) which may be installed some distance from the point of use, thus saving on water wastage.

product features

- Kwikot Prisma Classique Electric Water Heaters have a Glasslined Inner Cylinder, offering a long life to the cylinder (subject to water conditions equivalent to Metropolitan supply authorities).
- All units have a shiny non-corrosive polypropylene outer casing, which provides aesthetic appeal and will not discolour overtime.
- Thick polyurethane foam insulation is used to reduce inner cylinder heat loss.
- Units are fitted with a large sacrificial anode, providing additional inner cylinder protection.
- External Temperature Controls are fitted with a maximum temperature setting of 75°C.
- Capillary Thermostat for accurate temperature settings.
- Working pressure 0kPa.
- Fitted electrical cable with 15 Amp 3 Pin Electrical Plug.

product specification data

Units are tested to SANS 60335-2-21.

The Thermostat, will cutout when the required temperature is reached. The recommended setting is 60°C. Faulty Thermostats and Elements can be replaced when necessary.

Model	10lt Under Basin	10lt Over Basin	15lt Over Basin	30lt Over Basin
Weight (empty)	8.1kgs	7.9kgs	9.3kgs	14.0kgs
Electrical Supply	230V	230V	230V	230V
Wattage	1500	1500	1500	1500
Heating Time ($\Delta T=55^{\circ}\text{C}$)	26 minutes	26 minutes	40 minutes	80 minutes



product installation data

- Installation of the point of use electric water storage heater must be carried out by a qualified plumber.
- The Under Basin unit may only be fitted with a counter surface PUSH THROUGH MIXER (not supplied) and the Over Basin Unit with a over counter PUSH THROUGH MIXER (not supplied) or with STOP COCK and SPOUT (not supplied). These are available from Kwikot.

product warranty and anode servicing

- One year on the inner Glasslined cylinder and on the Element and Thermostat. The warranty on the inner cylinder is subject to water conditions equivalent to main metropolitan supply authorities.
- Warranties are applicable from date of purchase and validated by means of a purchase invoice submittance of a completed warranty card to Kwikot (card supplied with unit).
- The warranty is applicable in South Africa, Namibia, Lesotho, Swaziland and Botswana and subject to water conditions equivalent to main Metroploitan supply authorities
- **The Sacrificial Anode must be checked every six months for degradation and replaced if necessary.**

product dimensions

Product Code	FPRX-10-UB	FPRX-10-OB	FPRX-15-OB	FPRX-30-OB
Dimension	10lt Under Basin	10lt Over Basin	15lt Over Basin	30lt Over Basin
A (mm)	340	340	360	440
B (mm)	291	291	329	389
C (mm)	347	347	375	455
D (mm)	90	90	97	113
E (mm)	15 (1/2")	15 (1/2")	15 (1/2")	15 (1/2")

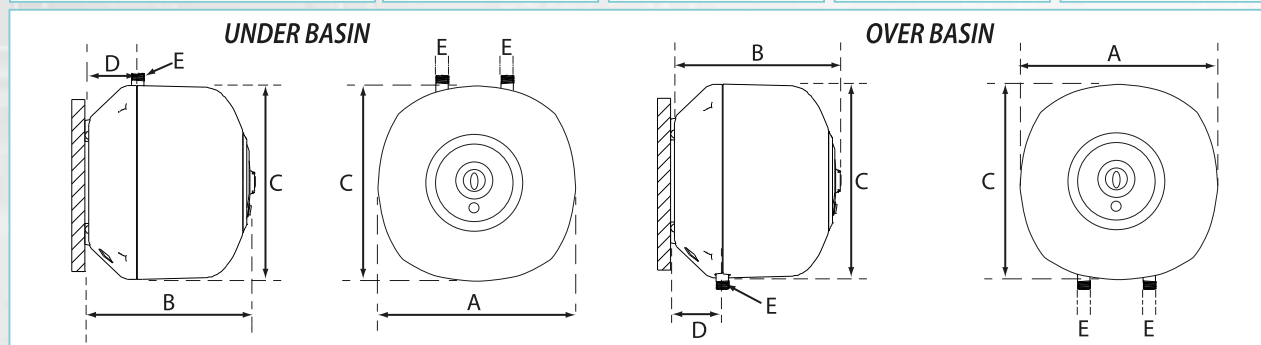

installation of the under basin unit

Allow sufficient space beneath the basin/sink for the unit and a 15 Amp wall socket should be within 1.5m of the unit.

1. Selecting a Position for the Mixer on the Basin/Sink (using the Kwikot Under Basin Mixer PMX-74)

- Select the side of the basin/sink most suited for the mixer hole and where the space is directly underneath the unit.
- Ideally the cold water connection should be on the same side as the mixer and under the basin/sink.
- Using a drilling machine with a hole saw for stainless steel sinks or acrylic basins drill the mounting hole. On ceramic basins the mounting hole should already be provided.
- Fit the mixer to the basin/sink and fit the flexible hoses to the mixer. Note the directional flow arrows on the hoses.

2. Mounting the Unit

- Hold the unit against the wall within reach of the mixer's flexible hoses and mark the unit's position.
- Remove the unit and drill two holes with a masonry drill bit to fix the hanging bracket to the wall. Minimum M8 size raw bolts should be used.
- Fix the bracket to the wall by means of the raw bolts and ensure that the bracket is level by using a split-level.
- Hang the unit onto the two hooks on the bracket.

3. Connecting the Mixer Pipes to the Unit and Water Supply Connection

- Position the hoses to line up with the hot and cold connection points on the unit.
- Using PTFE thread tape, screw the two hoses (hot and cold) onto the correct connections and the third hose connect to the main cold water supply, ensuring all hoses are tightly fastened.

4. Filling the Unit with Water

- Open the main cold water supply to the unit and the mixer.
- Open the cold water side of the mixer with the BLUE dot.
- Open the hot side of the mixer with the RED dot. Allow all the air to expel from the installation and for the water to flow freely from the spout.
- Close both the cold and hot sides on the mixer.
- **Ensure the unit is filled with water before connecting the electricity supply.**

5. Connecting the Electricity Supply

- Plug the 15 Amp electrical cable into the wall socket and switch "ON".
- Adjust the External Temperature Control to the desired setting (recommended 60°C) and switch "ON" the unit. The amber light will glow indicating that the water is been heated.

Important Note: After the first heating cycle of 26 minutes, depending on the size of the unit, drain off all the hot water to expel any contaminants i.e. solder flux.



prisma
Classique
POINT OF USE
ELECTRIC WATER HEATER



*Point of Use Electric Water Heaters with
Glasslined Inner Cylinder*

Installation of the over basin unit

The area above the basin/sink must be bricked or tiled with no window, a 15 Amp wall socket should be within 1.5m of the unit and a 15mm female cold water connection 350mm in the centre above the basin/sink.

1. Position for the Mixer (using the Kwikot Over Basin Mixer PMX-72) and Water Supply Connection

- Slide the chrome finishing trim onto the mixer and screw the mixer without the spout onto the 15mm female cold water connection. Make sure the spout connection points downwards and the mixer is tightened.
- Attach the spout.

2. Mounting the Unit

- The ideal height for the unit is +/-600mm from the top of the basin/sink to the bottom of the unit.
- Hold the unit against the wall and mark the unit's position.
- Remove the unit and drill two holes with a masonry drill bit to fix the hanging bracket to the wall. Minimum M8 size raw bolts should be used.
- Fix the bracket to the wall by means of the raw bolts and ensure that the bracket is level by using a split-level.
- Hang the unit onto the two hooks on the bracket.

3. Connecting the Mixer Pipes.

- Measure the length between the pipe connections on the bottom of the unit and the mixer and cut the pipes to size using a hacksaw or tube cutter.
- Slide the pipe nuts and sealing washers over the pipes and fit the pipes (hot and cold) onto the correct connections, ensuring all hoses are tightly fastened.

4. Filling the Unit with Water

- Open the main cold water supply to the unit and the mixer.
- Open the cold water side of the mixer with the BLUE dot.
- Open the hot side of the mixer with the RED dot. Allow all the air to expel from the installation and for the water to flow freely from the spout.
- Close both the cold and hot sides on the mixer.

• Ensure the unit is filled with water before connecting the electricity supply.

5. Connecting the Electricity Supply

- Plug the 15 Amp electrical cable into the wall socket and switch "ON".
- Adjust the External Temperature Control to the desired setting (recommended 60°C) and switch "ON" the unit. The amber light will glow indicating that the water is been heated.

Important Note: After the first heating cycle of 26 minutes, depending on the size of the unit, drain off all the hot water to expel any contaminants i.e. solder flux.



IPX4

IEC 60353-5-2-21

kwikot branch and website addresses:

**kwikot (pty) ltd
inland division**

PO Box 1016 Benoni 1500
Tel: (011) 897 4600
Fax: (011) 914 4750
Domestic Sales
email: sales.inland@kwikot.com
AFTER SALES SERVICE TEL:
0861 KWIKOT (594568)
Export Sales:
email: sales.export@kwikot.com
Marketing:
email: marketing.info@kwikot.com
Technical:
email: technical.info@kwikot.com

**kwikot (pty) ltd
eastern cape division**

PO Box 29142, Sunridge Park, Port Elizabeth, 6008
Tel: (041) 399 4000
Fax: (041) 367 1005
Domestic Sales
Email: sales.easterncape@kwikot.com

**kwikot (pty) ltd
western cape division**

PO Box 443, Eppindust, 7475
Tel: (021) 690 2700
Fax: (021) 690 2800
Domestic Sales
Email: sales.westerncape@kwikot.com

**kwikot (pty) ltd
kwazulu-natal division**

P O Box 47366, Greyville, 4023
Tel: (031) 574 8700
Fax: (031) 574 8750
Domestic Sales
email: sales.kwazulunatal@kwikot.com