

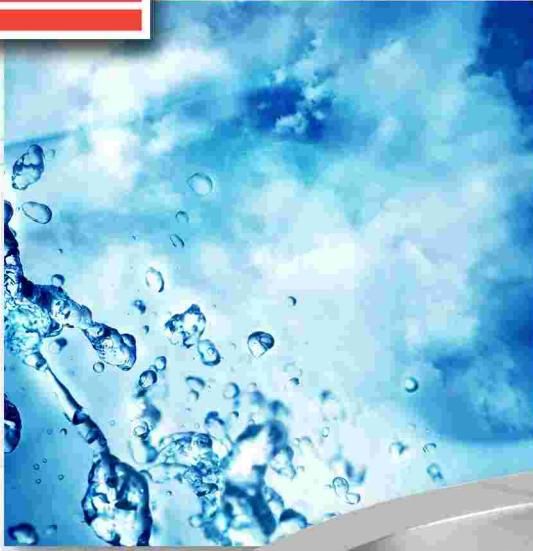

COMMERCIAL

stainless steel



**SANITARY
EQUIPMENT**
wall hung
wc pan

SWC - PAN - WM

SANITARY EQUIPMENT - WALL HUNG WATER CLOSET PAN



COMMERCIAL

stainless steel



WALL HUNG WC PAN MODEL SWC - PAN - WM

features

- Grade 304 (18/10) Stainless Steel
- Durable
- Hygienic
- Outer body totally enclosed
- Complies with paper removal test: SABS 497:2:006
- Complies with flushing test: SABS 1733:2007
- External surfaces of 1,2mm gauge. Mounting panel 3mm gauge.
- Integral "P" trap and WC shroud
- All plumbing built into wall
- Inlet and outlet to suit standard flush pipe/PVC or cast iron sewerage systems.
- Seat provision
- Fixed to wall with 12mm anchor bolts (Supplied by installer).

MODEL SWC-PAN-WM

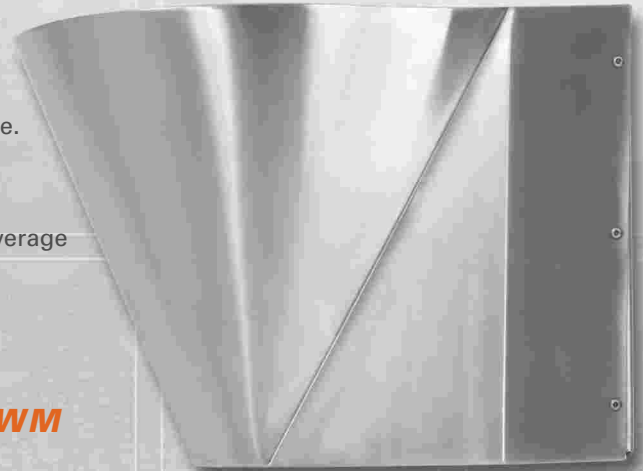

specifications for model SWC - PAN - WM

Kwikot Wall Hung WC Pan Code: SWC-PAN-WM manufactured from Grade 304 (18/10) Stainless Steel complete with pressed integral "P" trap and wall mounting bracket.

standard size for model SWC - PAN - WM

MODEL	HEIGHT (mm)	WIDTH (mm)	DEPTH
SWC-PAN-WM	576	380	576

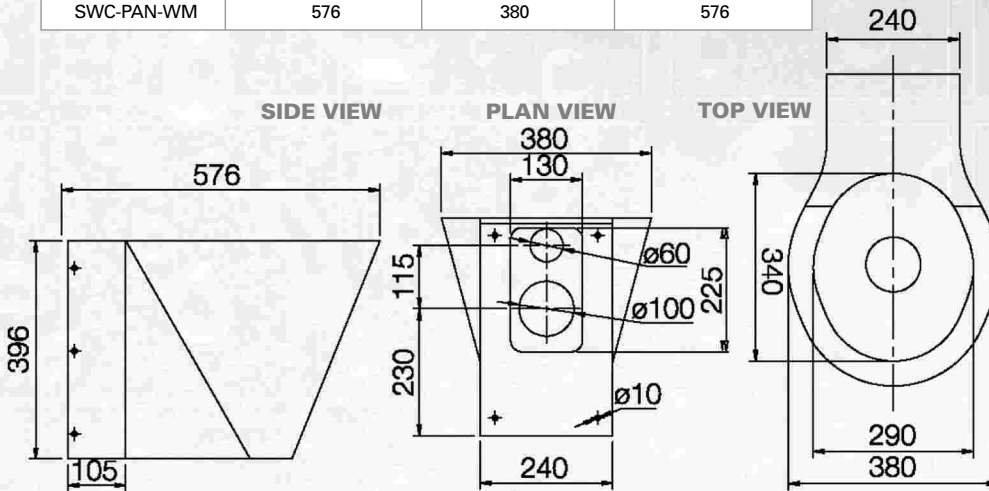
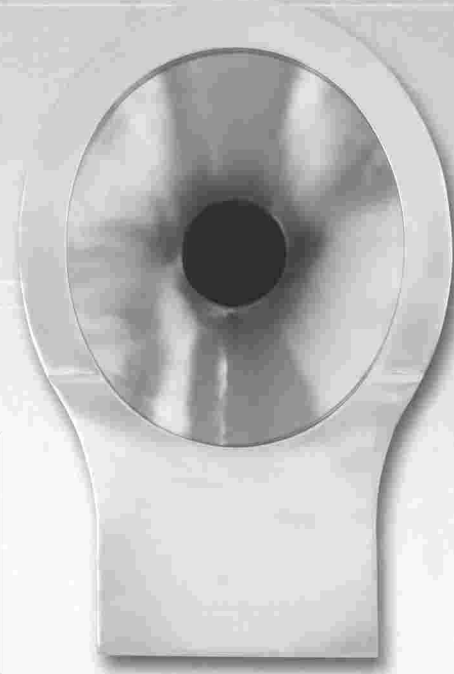

SANITARY EQUIPMENT - WALL HUNG WATER CLOSET PAN

**Kwikot (Pty) Ltd
Inland Division**
P.O. Box 1016
Benoni
1500
Tel: 0118974600
Fax: 0119144750

**Kwikot (Pty) Ltd
Kwazulu-Natal Division**
P.O. Box 47366
Greyville
Durban
4023
Tel: 0315748700
Fax: 0315748750

**Kwikot (Pty) Ltd
Eastern Cape Division**
P.O. Box 3082
North End
Port Elizabeth
6056
Tel: 0413730575
Fax: 0413730577

**Kwikot (Pty) Ltd
Western Cape Division**
P.O. Box 443
Eppingdust
Cape Town
7475
Tel: 0215343691
Fax: 0215341606

After Sales Service:
0861KWIKOT (594568)

www.kwikot.com

Kwikot, over a century of reliability