

# CATERING & INDUSTRIAL PRODUCTS

Product Guide



*Make  
it  
Wonderful*

**FRANKE**





## CATERING & INDUSTRIAL PRODUCTS

SINKS, TABLES, WALL BENCHES & SHELVING

Heavy duty industrial sinks and tables with sound deadening under frames.

The range is complimented by a selection of modular designed shelving systems for catering applications.



IMAGE	TYPE / MODEL	DIMENSIONS (L X W)	PRODUCT CODE
-------	--------------	--------------------	--------------



S1 RIGHT HAND BOWL  
2620015

## S1 Stainless Steel Catering Sinks

Franke model "S1" Catering Sink single end/centre (please specify) bowl manufactured from grade 304 stainless steel 1,2mm thick with a 150mm high integral splash back to the rear and 50x10mm turndown with a beaded edge on the remaining sides. Sink with pressed 500x500x230mm deep bowl with a 40mm waste outlet. The underside sprayed with vermin proof bitumastic sound deadening and supported with a 30x30x3mm framework and galvanised mild steel backing sheet. Unit fixed 900mm high from the top of the front apron to the finish floor level with anchor bolts (bolts specified elsewhere).

**Please refer to fixing table for fixing options (Pg8).**

- Pressed bowls 500x500x230mm deep
- Grade 304 (18/10) Stainless Steel 1.2mm gauge
- Fully sound deadened with galvanised backing sheet
- Hospital bead to prevent spillage
- 57 Litre Bowl Capacity

### OPTIONAL ACCESSORIES:

- Stainless steel solid under shelf
- Stainless steel slatted under shelf
- Splash backs to ends

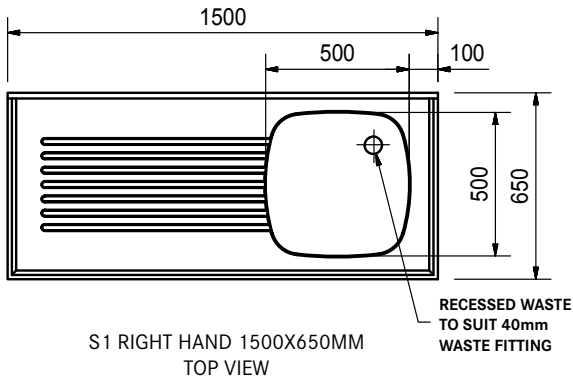

S1 RIGHT HAND 1500X650MM  
TOP VIEW

S1 LEFT HAND	1200x650mm	2620016
S1 RIGHT HAND	1200x650mm	2620015
S1 CENTRE	1200x650mm	2620258
S1 LEFT HAND	1500x650mm	2620003
S1 RIGHT HAND	1500x650mm	2620017
S1 CENTRE	1500x650mm	2620018

**Non-standard sizes available on request**

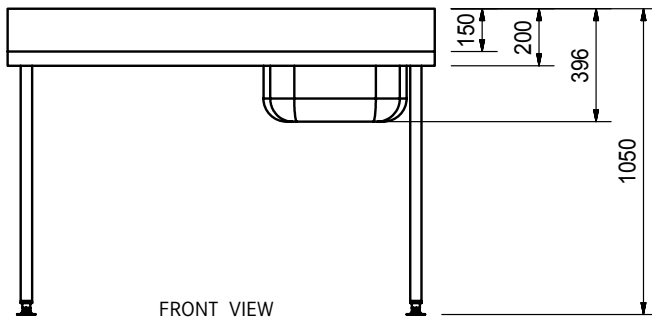

FRONT VIEW

IMAGE	TYPE / MODEL	DIMENSIONS (L X W)	PRODUCT CODE
-------	--------------	--------------------	--------------



## S2 Stainless Steel Catering Sinks

Franke model "S2" Catering Sink double end/centre (please specify) bowl manufactured from grade 304 stainless steel 1,2 mm thick with a 150mm high integral splash back to the rear and 50x10mm turndown with a beaded edge on the remaining sides. Sink with pressed 500x500x230mm deep bowl with a 40mm waste outlet. The underside sprayed with vermin proof bitumastic sound deadening and supported with a 30x30x3mm framework and galvanised mild steel backing sheet. Unit fixed 900mm high from the top of the front apron to the finish floor level with anchor bolts (bolts specified elsewhere).

**Please refer to fixing table for fixing options (Pg8).**

- Pressed bowls 500x500x230mm deep
- Grade 304 (18/10) Stainless Steel 1.2mm gauge
- Fully sound deadened with galvanised backing sheet
- Hospital bead to prevent spillage
- 57 Litre Bowl Capacity

TAP & FITTINGS NOT INCLUDED

### OPTIONAL ACCESSORIES:

- Stainless steel solid under shelf
- Stainless steel slatted under shelf
- Splash backs to ends

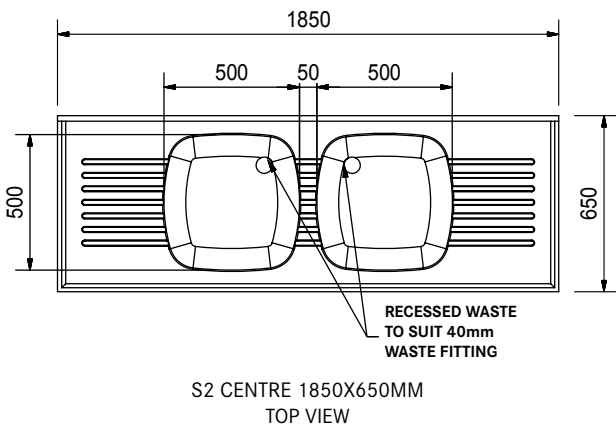

<b>S2 LEFT HAND</b>	1500x650mm	<b>2620005</b>
<b>S2 RIGHT HAND</b>	1500x650mm	<b>2620021</b>
<b>S2 CENTRE</b>	1500x650mm	<b>2620022</b>
<b>S2 LEFT HAND</b>	1850x650mm	<b>2620023</b>
<b>S2 RIGHT HAND</b>	1850x650mm	<b>2620024</b>
<b>S2 CENTRE</b>	1850x650mm	<b>2620025</b>
<b>S2 LEFT HAND</b>	2400x650mm	<b>2620004</b>
<b>S2 RIGHT HAND</b>	2400x650mm	<b>2620256</b>
<b>S2 CENTRE</b>	2400x650mm	<b>2620006</b>

**Non-standard sizes available on request**

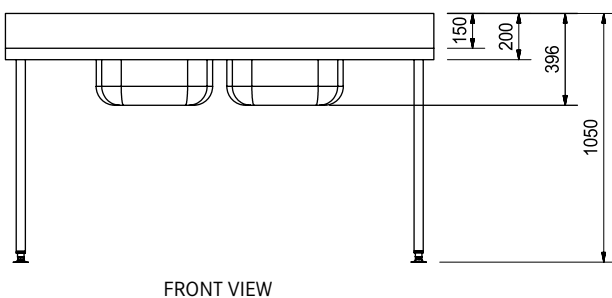

IMAGE	TYPE / MODEL	DIMENSIONS (L X W)	PRODUCT CODE
-------	--------------	--------------------	--------------



## P1 Stainless Steel Pot Sinks

Franke model "P1" Pot Sink single centre/end bowl (please specify) manufactured from grade 304 stainless steel 1,2mm thick with a 150mm high integral splash back to the back and 50x10mm turndown with a beaded edge on the remaining sides.. Sink with a pressed 600x500x300mm deep bowl with a 40mm waste outlet. The underside sprayed with vermin proof bitumastic sound deadening and supported with a 30x30x3mm framework and galvanised mild steel backing sheet. Unit fixed 900mm high from the top of the front apron to the finish floor level with anchor bolts (bolts specified elsewhere).

**Please refer to fixing table for fixing options (Pg8).**

- Grade 304 (18/10) Stainless Steel 1.2mm gauge
- Sound deadened with galvanised backing sheet
- Hospital bead to prevent spillage
- 90 Litre Bowl Capacity

### OPTIONAL ACCESSORIES:

- Stainless steel solid under shelf
- Stainless steel slatted under shelf
- Splashback to ends

**P1 CENTRE BOWL** 900x650mm

**2620481**

**Non-standard sizes available on request**

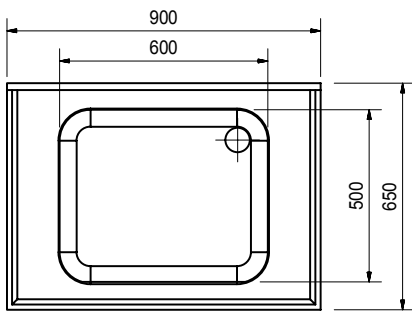

TOP VIEW

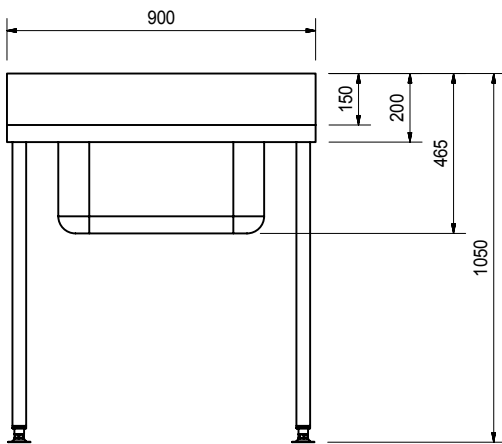

FRONT VIEW

IMAGE	TYPE / MODEL	DIMENSIONS (L X D X W)	PRODUCT CODE
-------	--------------	------------------------	--------------



## P2 Stainless Steel Pot Sinks

Franke model "P2" Pot Sink double centre/end (please specify) bowl pot sink, manufactured from grade 304 stainless steel 1,2mm thick with a 150mm high integral splash back and 50x10mm turndown with a beaded edge on the remaining sides. Sink with a pressed 600x500x300mm deep bowl with a 40mm waste outlet. The underside sprayed with vermin proof bitumastic sound deadening and supported with a 30x30x3mm framework and galvanised mild steel backing sheet. Unit fixed 900mm high from the top of the front apron to the finish floor level with anchor bolts (bolts specified elsewhere).

**Please refer to fixing table for fixing options (Pg8).**

- Grade 304 (18/10) Stainless Steel 1.2mm gauge
- Sound deadened with galvanised backing sheet
- Hospital bead to prevent spillage
- 90 Litre Bowl Capacity

### OPTIONAL ACCESSORIES:

- Stainless steel solid under shelf
- Stainless steel slatted under shelf
- Splashback to ends

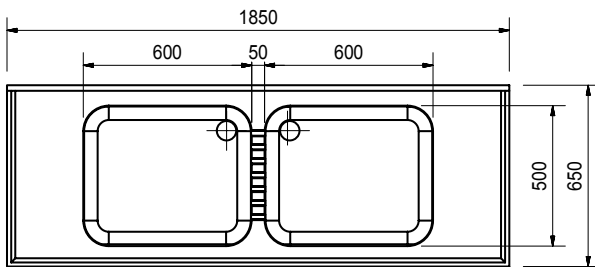

TOP VIEW

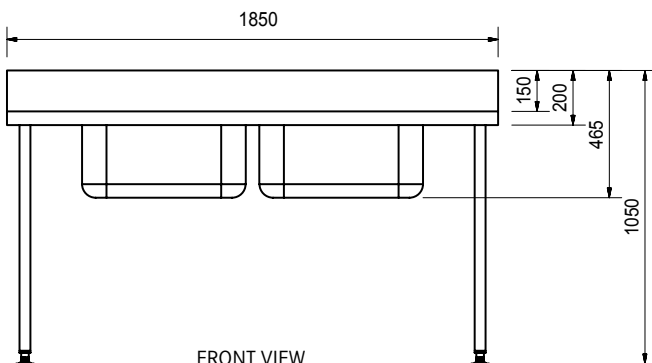

FRONT VIEW

<b>P2 CENTRE</b>	1850x650mm	<b>2620482</b>
<b>P2 LEFT HAND</b>	2400x650mm	<b>2620483-001</b>
<b>P2 RIGHT HAND</b>	2400x650mm	<b>2620483-002</b>
<b>P2 CENTRE</b>	2400x650mm	<b>2620483</b>

**Non-standard sizes available on request**

IMAGE	TYPE / MODEL	DIMENSIONS (L X D X W)	PRODUCT CODE
-------	--------------	------------------------	--------------



LEFT HAND BOWL

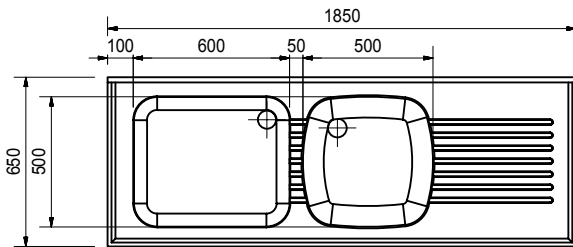

LEFT HAND BOWL  
TOP VIEW

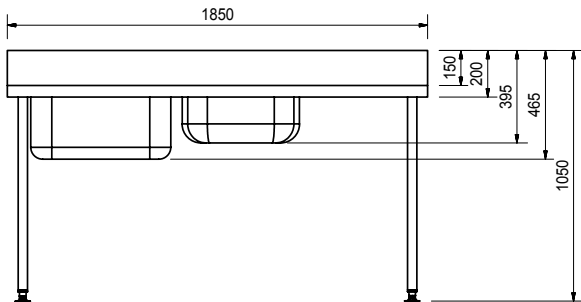

LEFT HAND BOWL  
FRONT VIEW

## S1P1 Double Bowl Preparation Sinks

Franke model S1P1 double bowl Preparation sink manufactured from grade 304 stainless steel 1,2mm thick with a 150mm high integral splash back to the back and 50x10mm turndown with a beaded edge on the remaining sides. Sink with a pressed catering bowl 500x500x230mm deep and a pressed pot sink bowl 600x500x300mm deep with 40mm waste outlets. The underside sprayed with vermin proof bitumastic sound deadening and supported with a 30x30x3mm framework and galvanised mild steel backing sheet. Unit fixed 900mm high from the top of the front apron to the finish floor level with anchor bolts (bolts specified elsewhere).

**Please refer to fixing table for fixing options (Pg8).**

- Grade 304 (18/10) Stainless Steel 1.2mm gauge
- Sound deadened with galvanised backing sheet
- Hospital bead to prevent spillage
- 1 x 57 Litre Bowl Capacity
- 1 x 90 Litre Bowl Capacity

### OPTIONAL ACCESSORIES:

- Stainless steel solid under shelf
- Stainless steel slatted under shelf
- Splash back to ends

**S1P1 LEFT HAND** 1850x650mm **2620485**

**S1P1 RIGHT HAND** 1850x650mm **2620484**

**Non-standard sizes available on request**



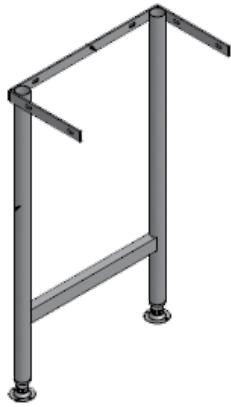

40mm DIAMETER ROUND LEG (PAIR)

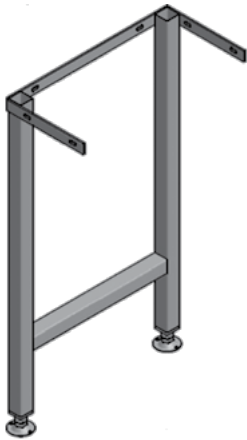

40 x 40mm SQUARE LEG (PAIR)

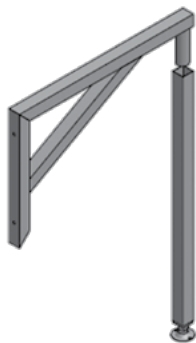

GALLOWS BRACKET WITH REMOVABLE FRONT LEG

## Fixing Options For S & P Type Sinks

### STAINLESS STEEL ROUND LEGS

Round Legs manufactured from grade 304(18/10) stainless steel 41mm diameter x 1,2mm thick round tubing. Legs to be detachable and fitted with chrome plated adjustable flanged foot pieces.

### STAINLESS STEEL SQUARE LEGS

Square Legs manufactured from grade 304(18/10) stainless steel 40x40mm x 1,2mm thick square tubing. Legs to be detachable and fitted with chrome plated adjustable flanged foot pieces.

### STAINLESS STEEL GALLOWS BRACKETS WITH FRONT LEG

Gallows Brackets with Front Legs manufactured from grade 304(18/10) stainless steel 40x40mm x 1,2mm thick square tubing. The front leg is detachable and is fitted with chrome plated adjustable flanged foot pieces.

**\*These brackets are used in areas where the floors have coved skirting.**

### STAINLESS STEEL CANTILEVER BRACKETS

Cantilever Brackets manufactured from grade 304(18/10) stainless steel 40x40mm x 1,2mm thick square tubing.

**\*These brackets are used in areas where the floors have coved skirting and the design makes cleaning under the unit very easy.**

METHOD	COMMENTS	QTY REQ.	PRODUCT CODE
40mm diameter round legs	Units 2400 mm and longer require additional legs	2 pairs	<b>2120033</b>
40x40mm square legs	Units 2400 mm and longer require additional legs	2 pairs	<b>2120031</b>
40x40mm square gallows bracket with detachable front leg	Units 2400 mm and longer require additional bracket and leg	1 pair	<b>2120021</b>
40x40mm cantilever bracket	Units 2400 mm and longer require additional brackets	1 pair	<b>2120022</b>

## RECOMMENDED FIXING OPTION

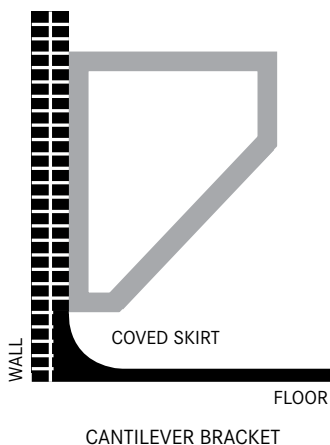

IMAGE	TYPE / MODEL	DIMENSIONS (L X D X W)	PRODUCT CODE
-------	--------------	------------------------	--------------



## Stainless Steel Tables

Franke model T Table manufactured from grade 304 stainless steel 1,2mm thick with a 50x10mm turndown all round. The underside sprayed with vermin proof bitumastic sound deadening and supported with a 30x30x3mm framework and galvanised mild steel backing sheet. Unit fixed 900mm high from the top of the front apron to the finish floor level with anchor bolts (bolts specified elsewhere).

**Please refer to fixing table for fixing options (Pg 11).**

- Grade 304 (18/10) Stainless Steel, 1.2mm gauge
- Sound deadened with galvanised back sheet

### OPTIONAL ACCESSORIES:

- Stainless or mild steel galvanised solid undershelf
- Stainless or mild steel galvanised slatted undershelf

1500x650mm	<b>2620100</b>
1850x650mm	<b>2620103</b>
2400x650mm	<b>2620108</b>

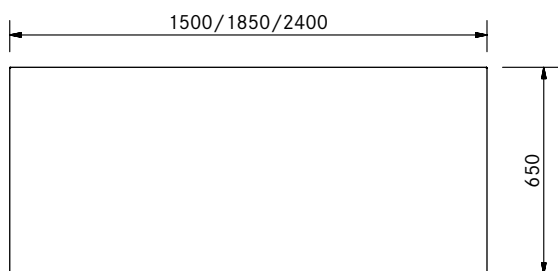

TOP VIEW



FRONT VIEW

**Non-standard sizes available on request**

IMAGE	TYPE / MODEL	DIMENSIONS (L X D X W)	PRODUCT CODE
-------	--------------	------------------------	--------------



## Stainless Steel Wall Benches

Franke model W Wall Bench manufactured from grade 304 stainless steel 1,2mm thick with a 150mm integral splash back at the back and 50x10mm turndown on the remaining sides. The underside sprayed with vermin proof bitumastic sound deadening and supported with a 30x30x3mm framework and galvanised mild steel backing sheet. Unit fixed 900mm high from the top of the front apron to the finish floor level with anchor bolts (bolts specified elsewhere).

**Please refer to fixing table for fixing options (Pg 11) .**

- Grade 304 (18/10) Stainless Steel, 1.2mm gauge
- Sound deadened with galvanised back sheet

### OPTIONAL ACCESSORIES:

- Stainless or mild steel galvanised solid under shelf
- Stainless or mild steel galvanised slatted under shelf
- Splash backs to ends

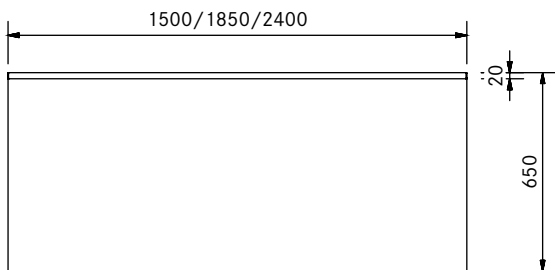

TOP VIEW

1500x650mm

**2620114**

1850x650mm

**2620117**

2400x650mm

**2620122**

**Non-standard sizes available on request**

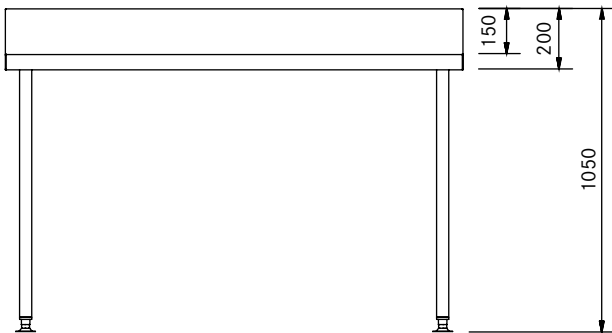

FRONT VIEW

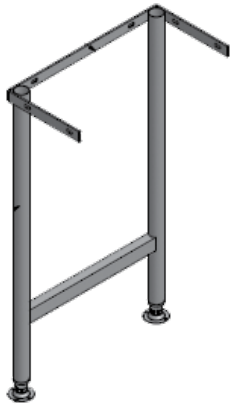

40mm DIAMETER ROUND LEG (PAIR)

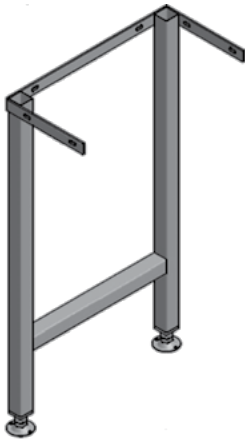

40 x 40mm SQUARE LEG (PAIR)

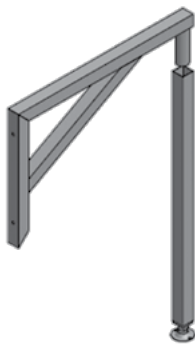

GALLOWS BRACKET WITH REMOVABLE FRONT LEG

**Fixing Options For Tables & Wall Benches**

**STAINLESS STEEL ROUND LEGS**

Round Legs manufactured from grade 304(18/10) stainless steel 41mm diameter x 1,2mm thick round tubing. Legs to be detachable and fitted with chrome plated adjustable flanged foot pieces.

**STAINLESS STEEL SQUARE LEGS**

Square Legs manufactured from grade 304(18/10) stainless steel 40x40mm x 1,2mm thick square tubing. Legs to be detachable and fitted with chrome plated adjustable flanged foot pieces.

**STAINLESS STEEL GALLOWS BRACKETS WITH FRONT LEG**

Gallows Brackets with Front Legs manufactured from grade 304(18/10) stainless steel 40x40mm x 1,2mm thick square tubing. The front leg is detachable and is fitted with chrome plated adjustable flanged foot pieces.

**\*These brackets are used in areas where the floors have coved skirting.**

**STAINLESS STEEL CANTILEVER BRACKETS**

Cantilever Brackets manufactured from grade 304(18/10) stainless steel 40x40mm x 1,2mm thick square tubing.

**\*These brackets are used in areas where the floors have coved skirting and the design makes cleaning under the unit very easy.**

METHOD	COMMENTS	QTY REQ.	PRODUCT CODE
40mm diameter round legs	units 2400 mm and longer require additional legs	2 pairs	<b>2120023</b>
40x40mm square legs	units 2400 mm and longer require additional legs	2 pairs	<b>2120024</b>
40x40mm square gallows bracket with detachable front leg	units 2400 mm and longer require additional bracket and leg	1 pair	<b>2120026</b>
40 x 40mm cantilever bracket	units 2400 mm and longer require additional brackets	1 pair	<b>2120027</b>

**RECOMMENDED FIXING OPTION**

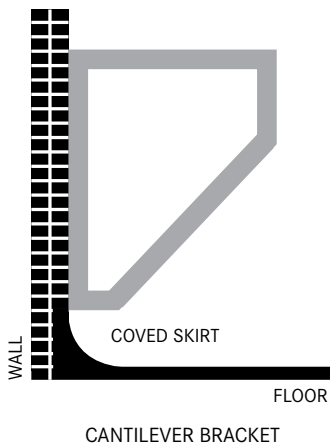
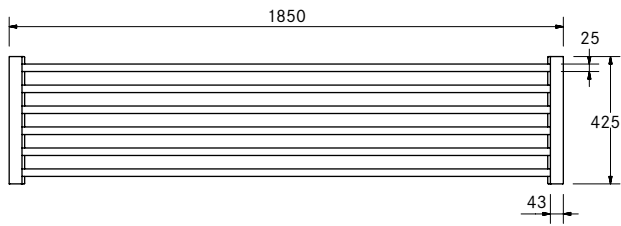
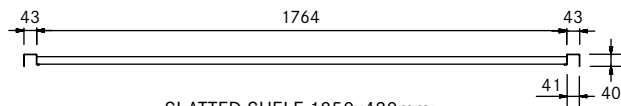

IMAGE	TYPE / MODEL	DIMENSIONS (L X D X W)	PRODUCT CODE
-------	--------------	------------------------	--------------



SLATTED SHELF 1850x420mm:  
TOP VIEW



SLATTED SHELF 1850x420mm:  
FRONT VIEW

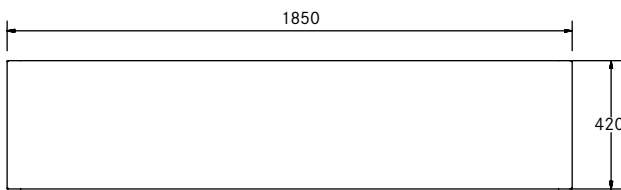

SOLID SHELF 1850x420mm  
TOP VIEW

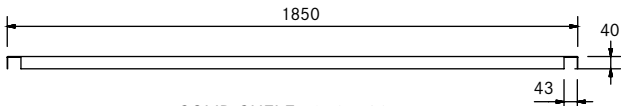

SOLID SHELF 1850x420mm  
FRONT VIEW

## Franke Model Under Shelves for Sinks and Tables

Solid Shelves manufactured from grade 304 stainless steel 1.2mm thick. Shelf designed to fit over the cross braces on the legs.

Slatted Shelves manufactured from 22mm diameter grade 304 stainless steel tubing. Shelf designed to fit over the cross braces on the legs.

Sizes available:

1. 900x420mm
2. 1850x420mm
3. 2400x420mm
4. Variousx420mm

NB: Please specify requirements:

- a) stainless steel or mild steel
- b) solid or slatted
- c) required size

Stainless Solid	1500x420mm	<b>2620043</b>
Stainless Slatted	1500x420mm	<b>2620044</b>
Stainless Solid	1850x420mm	<b>2620086</b>
Stainless Slatted	1850x420mm	<b>2620093</b>
Stainless Solid	2400x420mm	<b>2620088</b>
Stainless Slatted	2400x420mm	<b>2620095</b>

**Non-standard sizes available on request**

IMAGE	TYPE / MODEL	DIMENSIONS (L X W)	PRODUCT CODE
-------	--------------	--------------------	--------------



## Fastrack Modular Shelving

Franke Model Fastrack Modular Shelving Solid/Louvred (please specify)  
Shelves manufactured from 1.2mm thick grade 304 (18/10) stainless steel with die cast aluminium corner brackets for fixing to Ø 25mm vertical posts.

Posts are made from 1.2mm thick Ø 25mm diameter stainless steel and fitted with end caps at one end and adjustable foot piece.

- Modular - easy to assemble, expand and adjust
- Mobile - suitable for many applications
- Durable - constructed and designed to the highest standards of strength and hygiene

### OPTIONAL EXTRAS:

- Set of four castors 125mm ø/two lockable

TYPE OF SHELF	DIMENSIONS (L X W)	PRODUCT CODE
---------------	--------------------	--------------

### Standard Shelving Sizes

Solid	750x400mm	<b>2620051</b>
Solid	750x500mm	<b>2620055</b>
Louvred	750x400mm	<b>2620059</b>
Louvred	750x500mm	<b>2620063</b>
Solid	1000x400mm	<b>2620052</b>
Solid	1000x500mm	<b>2620056</b>
Louvred	1000x400mm	<b>2620060</b>
Louvred	1000x500mm	<b>2620064</b>
Solid	1250x400mm	<b>2620053</b>
Solid	1250x500mm	<b>2620057</b>
Louvred	1250x400mm	<b>2620061</b>
Louvred	1250x500mm	<b>2620065</b>
Solid	1500x400mm	<b>2620054</b>
Solid	1500x500mm	<b>2620058</b>
Louvred	1500x400mm	<b>2620062</b>
Louvred	1500x500mm	<b>2620066</b>

### Non-standard sizes available on request

#### Stainless steel posts with 1,2mm wall thickness 25mm ø:

1000mm	<b>2620027</b>
1500mm	<b>2620028</b>
1800mm	<b>2620029</b>
2000mm	<b>2620030</b>

### Non-standard sizes available on request

#### Posts with castors:

1000mm	<b>2620031</b>
1500mm	<b>2620032</b>
1800mm	<b>2620032-001</b>
2000mm	<b>2620033</b>

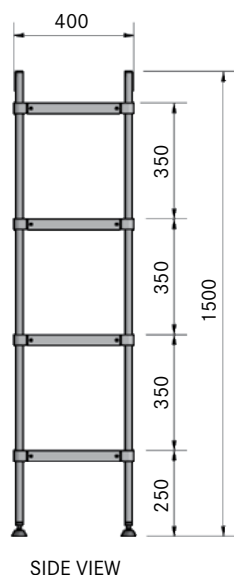
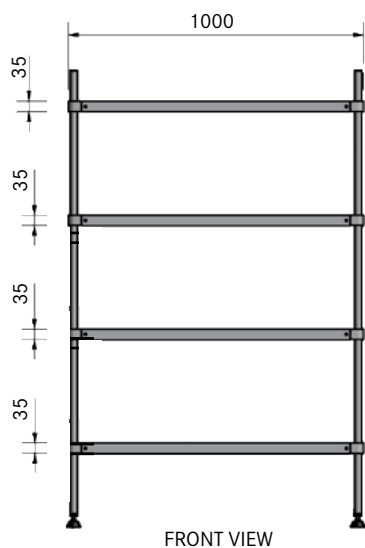

IMAGE	TYPE / MODEL	DIMENSIONS (L X W)	PRODUCT CODE
-------	--------------	--------------------	--------------



## Z-Series Shelving

Franke Model Z-Series Adjustable Shelving manufactured from grade 18/10 stainless steel 1,2mm thick. One piece shelf and integrated bracket with a 25mm apron to front and sides with 30mm turn up at back and safety edge on corners.

### WALL BANDS

Franke Model Z-Series Wall Bands manufactured from grade 18/10 Stainless Steel 1,2mm thick. Available in 1000mm; 1500mm and 1800mm Lengths and are double slotted to allow for two shelves to be lined up next to each other on a single wall band with very little space between shelves.

- Modular - easy to assemble, expand and adjust
- Durable - constructed and designed to the highest standards of strength and hygiene

### OPTIONAL EXTRAS:

- Grade 316 Stainless Steel, Solid or Perforated Shelves, 300 or 400mm Wide Shelves.

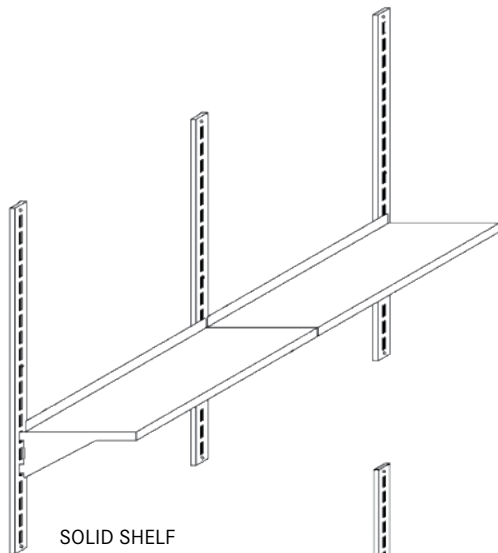

SOLID SHELF

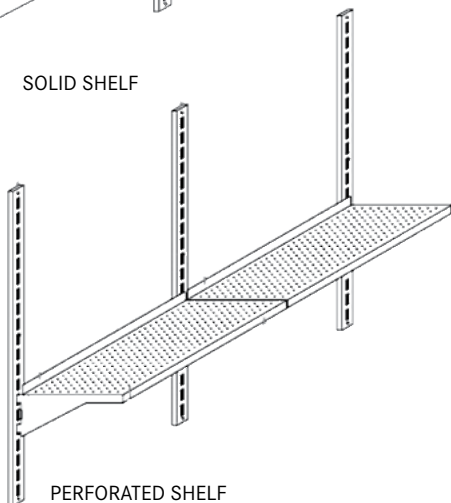

PERFORATED SHELF

### Standard Shelving Sizes

Solid	900x300mm	<b>2620036</b>
Perforated	900x300mm	<b>2620035</b>
Solid	900x400mm	<b>2620037</b>
Perforated	900x400mm	<b>2620038</b>
Solid	1200x300mm	<b>2620040</b>
Perforated	1200x300mm	<b>2620039</b>
Solid	1200x400mm	<b>2620042</b>
Perforated	1200x400mm	<b>2620041</b>

### Non-standard sizes available on request

### Stainless steel Wall Band

1000 mm L	<b>2620125</b>
1500 mm L	<b>2620124</b>
1800 mm L	<b>2620126</b>

### Non-standard sizes available on request

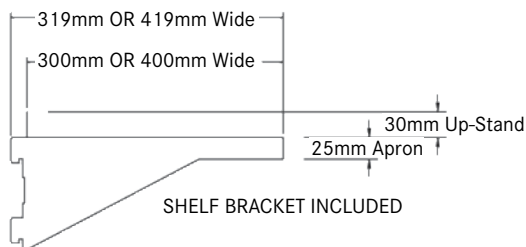

SHELF BRACKET INCLUDED

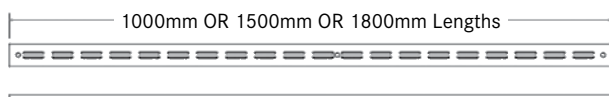

WALL BAND







# OTHER FRANKE PRODUCTS

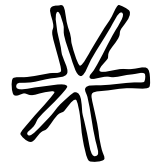

## Other Franke Products



### Washroom Accessories

Franke have a wide range of stainless steel accessories for all applications; hands free, wall mounted and recessed accessories. Our product range includes solid stainless steel bathroom accessories, ideally suited for such applications as: hospitals and clinics. The new Rodan range of accessories, its timeless design with angular side profiles lends itself to the contemporary décor of heavily frequented washrooms and rest rooms.



### Hands Free Accessories

Franke always strives to find the ultimate hygiene solutions without compromising quality and durability. The hands free accessories offer a hygienic solution for usage in heavily frequented washrooms, wards and rest rooms. The range includes a sensor operated: soap dispenser, paper towel dispenser and hand dryer.



### Grab Rails

Franke grab rails offer a secure support, thanks to Franke's Fine-Grip surface finish, for use in private homes and public, clinical and care sectors.



### Water Management

Complementing the Franke range of accessories, a new range of self closing/sensor operated basin taps and mixers have been added. The taps and mixers are of a heavy duty design to improve hygiene and decrease water consumption in public ablutions. The range comprises of an electronic sensor operated mixer and self closing taps and mixers.



### Filterflow Water Purification Mixer

Discover the unique advantages and health benefits of the Franke Filterflow water filtration system. Designed and fitted with a premium-grade carbon activated cartridge, the Franke Filterflow is a health-conscious and quality drinking water filtration system. The Filterflow dispenses hot, cold and perfectly filtered drinking water. The filtration system has the ability to filter out chlorides, odours and sedimentation from the water, it however does not 'strip' the water of its goodness and retains beneficial minerals such as calcium and magnesium - essential for a healthy diet.



### Zip Hydroboils & Chillers

Zip HydroBoils are convenient plumbed-in boiling water systems that deliver instant boiling water 24 hours a day. It is a sealed system to provide ultimate hygiene and low electricity consumption. It is steam free and low maintenance. Zip chillers are manufactured to provide chilled water under extreme temperatures. The units are plumbed to provide low operating costs, together with convenience.

### Sanitaryware



The use of Stainless Steel as the material of first choice for products in public and semi-public washrooms has become today's standard for good reasons. This material is robust and, easy to maintain, and therefore is very durable which makes the products economical over the lifetime of the building. Sanitary fixtures that inhibit vandalism and are easy to clean help building operators to keep service and maintenance costs to a minimum.

Practical experience shows that using high-quality materials reduces the staining of products that helps to maintain the appearance of heavily used washrooms. Wash stations and accessories take on a hygienic atmosphere. Thanks to its durable and hygienic characteristics, Stainless Steel provides clean and, safe products for public washrooms.



**DEKO 190V**



**DEKO 2000**

### DEKO 190V

The DEKO 190 has a large wash chamber and capacity for automatic emptying and processing of 2 bedpans with lids and 4 urine bottles simultaneously. The integrated drop down shelf provides space for 4 hand wash basins or a mop bucket with seating ring. The shelf can also be utilised as a base to accommodate and process inserts and washing accessories e.g. kidney dishes, bowls, vases, toilet brushes/holders, as well as, various hollowware.

**DEKO 190 Base Model**

**2800006**

### DEKO 2000

The DEKO 2000 is designed and constructed to meet the performance and design requirements stated in EN ISO 15883-1 Washer-disinfectors. Part 1: General requirements and in Part 2: Requirements and tests for surgical instruments, anaesthetic and respiratory equipment, hollowware, utensils, glassware etc., as well as, the safety requirements stated in IEC 61010-2-40: Particular requirements for washer-disinfectors used in medical, pharmaceutical, veterinary and laboratory fields.

**DEKO 2000 Base Model**

**2800004**



**DEKO 260**



**DEKO 2200**

### DEKO 260 Washer Disinfector

The DEKO 260 washer-disinfector-dryer is designed and manufactured to be fully compliant with the requirements of ISO EN 15883 Parts 1 & 2. It builds on the already well proven reliability and simple operation synonymous with Franke and ensures thorough cleaning and efficient processing of reusable medical and laboratory equipment.

**DEKO 260 Base Model**

**2800003**

### DEKO 2200

DEKO 2200 Drying cabinet is designed especially for drying surgical instruments, anaesthetic hoses & equipment, as well as other reusable items used in patient health care. It is dimensioned particularly for use together with the DEKO-2000 -series washer- disinfectors. The chamber can accommodate two full loads (4+4 shelves) from the washers. The sound and heat insulated double walls of the cabinet are made of AISI304 stainless steel. DEKO 2200 is available as a single door or pass-through model, left or right-hinged.

**DEKO 2200 Dryer**

**2800002**

FRANKE SOUTH AFRICA

CALL CENTRE

Tel 0861 372 653

Fax 0866 592 073

enquiry.fsa@franke.com

www.franke.co.za

DURBAN

1194 South Coast Road,

Mobeni, Durban, 4092.

South Africa

Tel +27 31 450 6300

Fax +27 31 450 6304

GAUTENG

77 Roan Crescent,

Sage Corporate Park North,

Old Johannesburg Road,

Midrand, 1682

South Africa

CAPE TOWN

Unit 1, 10 Gold Street,

Northgate Business Park, Northgate Estate,

Cape Town, 7405

South Africa

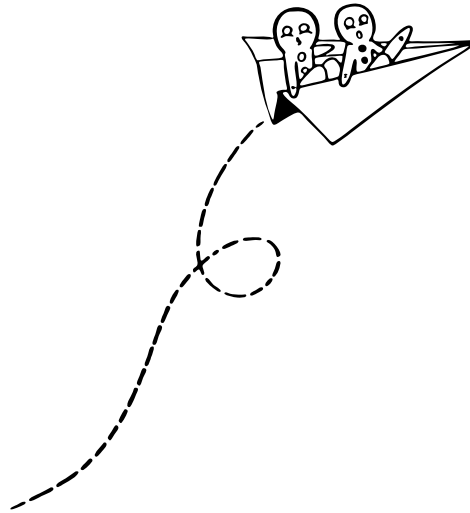

DISCLAIMER

The information and dates supplied in this brochure are based on the information believed to be reliable, however are not binding and inaccuracies may occur. Franke reserves the right to change Specification and design at any time without notice.

© 2017 by Franke South Africa. All rights reserved under the Copyright Act of 1987 with the amendments. Reproduction of any of the content, full or partial, is allowed only with prior written approval of Franke South Africa. No reasonable requests will be refused provided the conditions as laid out are met.



Make  
it  
wonderful