



**PARTITIONING
SOLUTIONS**

PARTITIONING SOLUTIONS



CONTENTS

01	Lafarge Plasterboard	04
02	Lafarge Fixed Partition	12
03	Lafarge Finesse Remountable Partition	36
04	Lafarge Compounds	48

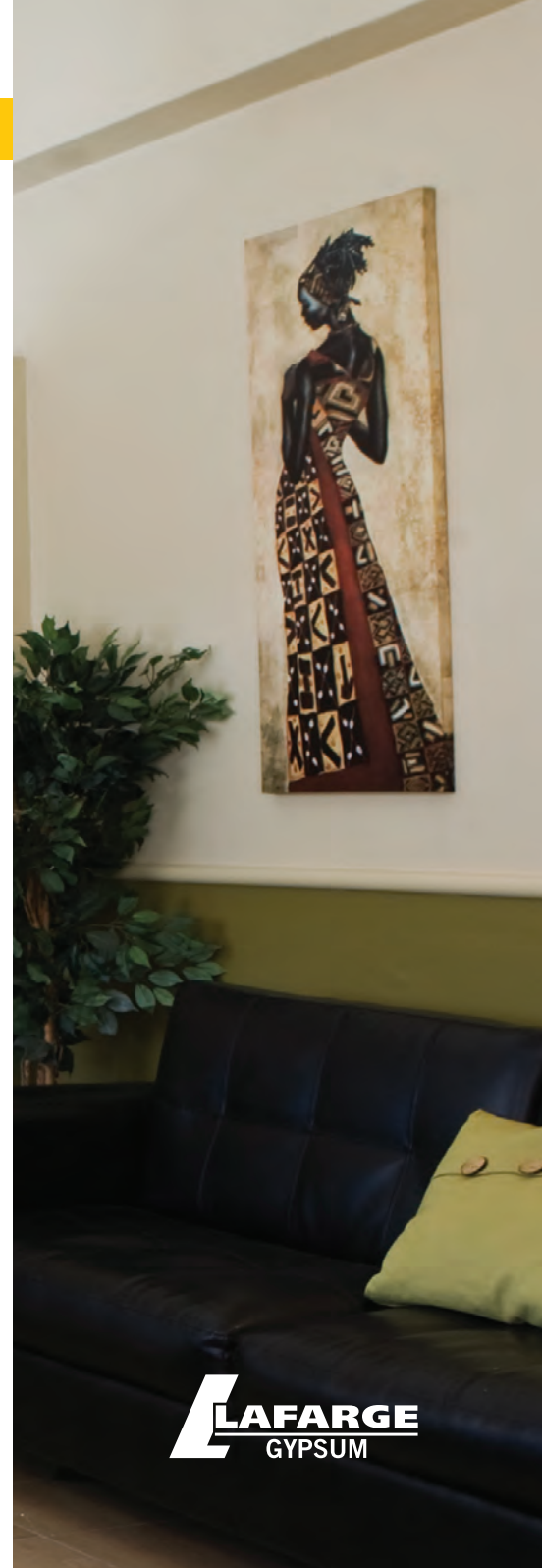

THE QUESTION OF QUALITY VERSUS SPEED HAS ALWAYS BEEN A CONTENTIOUS ONE IN THE INTERIOR DESIGN. ECONOMICS AND DEMAND REQUIRE BUILDINGS TO GO UP QUICKLY AND AFFORDABLY, WHICH COULD COMPROMISE QUALITY.

LAFARGE PLASTERBOARD

LAFARGE GYPSUM PLASTERBOARD

Lafarge Gypsum Plasterboard consists of an aerated gypsum core encased in and firmly bonded on both sides with special plasterboard liner, rendering a smooth yet highly functional surface. Special characteristics of gypsum provide the outstanding advantages over other flat sheet materials.

The board is fabricated by a modern automatic process with the supervision of highly experienced engineers and chemists.

The question of quality versus speed has always been a contentious one in interior design. Economics and demand require buildings to go up quickly and affordably, which could compromise quality.

Lafarge Gypsum Plasterboard: Designed for internal walls, ceilings and partitions in residential and commercial buildings, is quick and easy to install, while still being durable, recyclable, aesthetic and of superior quality without the necessary drying time for alternate wet trade solutions.

WANT TO KNOW WHAT SEPARATES A GREAT INTERIOR FROM THE AVERAGE?

HIGH QUALITY, ECOSPECIFIER LISTED, LAFARGE GYPSUM PLASTERBOARD

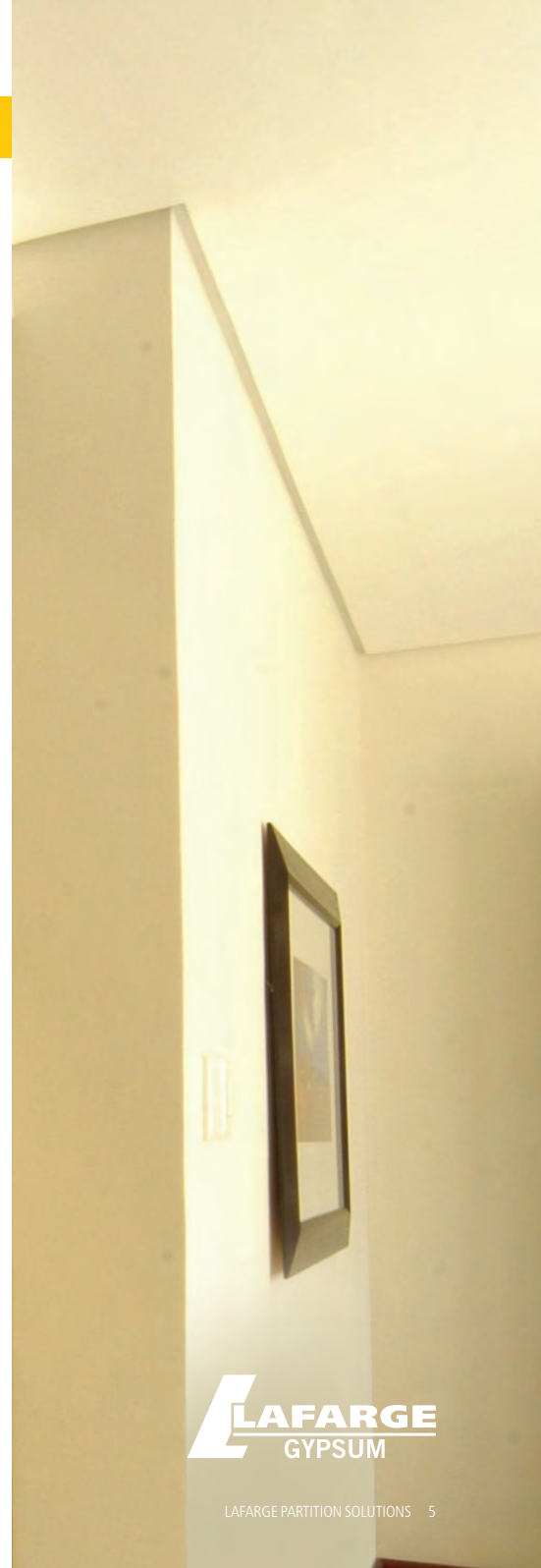

There are three types of Lafarge Plasterboard available from Lafarge Gypsum: **Standard, Fire Resistant and Moisture Resistant.**

Lafarge Standard Plasterboards are exceptionally versatile and lightweight. They can be used for domestic and commercial ceiling applications as well as walling/partitioning applications. Lafarge Plasterboard is also used to make prefabricated bulkheads, curved ceilings (barrel) and radiused walls among other innovative applications. Lafarge Plasterboard is a durable, versatile product that is clean and recyclable.

When combined with our Lafarge Ceiling Grid suspension system or our Steel Brandering, an extremely flat ceiling surface is achieved.

Lafarge Extra Fire Resistant Plasterboard is recommended for drywalling in kitchens and areas where additional fire resistance is required.

All of our Lafarge Plasterboards are tested at SABS Pretoria Fire Testing facility to SANS 10177 part 2 - 2005. Walls can be designed to suit your fire rating requirements up to a 2 hour fire rating.

Lafarge Moisture Resistant Plasterboard is recommended for use in all wet areas such as bathroom showers, as well as locations with high humidity levels. Lafarge Moisture Resistant Plasterboard is supported with special additives in the core, to retard the absorption rate of moisture, ensuring that the Lafarge Plasterboard maintains its high performance level over time.

Our boards have two different edges:

1. Square Edge (S.E.) for coverstrip jointing; visible butt jointed paneling with clamp fixing and fee suspension.



2. Tapered Edge (T.E.) for smooth and seamless jointing; jointless wall and ceiling paneling.



Lafarge Plasterboard Dimensions

	Thickness (mm)	Width	Length (mm)	Weight kg/m ² (Approx)	Use
Square Edge	6.4	1 200 900	2 400; 2 700; 3 000; 3 300; 3 600	5.50	Ceilings
	9		<i>S/E can be manufactured to order with minimum quantities</i>		
	12	1 195	2 400; 2 700; 3 000	9.50	Partitions

	Thickness (mm)	Width	Length (mm)	Weight kg/m ² (Approx)	Use
Tapered Edge	9	1 200	2 400; 2 700; 3 000; 3 600	7.30	Ceilings
	12	1 200	2 400; 2 700; 3 000; 3 300; 3 600	9.50	Partitions
	15	1 200	2 400; 2 700; 3 000; 3 600	14.0	Partitions

CHARACTERISTIC OF LAFARGE PLASTERBOARD

Lafarge goes to great lengths to ensure that the end-user receives quality products. Testing at the South African Bureau of Standards is an ongoing process and every effort is made to ensure testing is as close to site conditions as possible.

Some of the most important tests are as follows:

- Fire resistant SANS 10177 part 2 – 2005
Here a wall measuring 2.7 by 2.7m is placed in the opening of a furnace, and fired up to simulate actual fire conditions. The wall is subjected to this fire and heat for a limited duration of time as per our request - i.e. 30 minutes/60 minutes or 120 minutes, depending on the system being tested.

The Lafarge wall must be able to withstand 3 important criteria, namely Fire Stability (load bearing capacity), Fire Integrity (tightness against flame, gas and other leakages) and Fire Insulation (180 degrees plus ambient is the cut-off limit), before a fire rating can be issued to the system.

Other Tests:

- Gridlock deflection - SANS 7228/158EMT01
- Sag Test BS 8290
- Sag Test TDC M03-TDC-022D
- SANS/ASTM 367-89
- 7228/013/MT01/REVA
- 5544/158C/MT01
- 7228/158C/MT01
- 7228/112A/MT01
- Pull Test Lafarge Gypsum - TDC M02-TDC-023-D

Storage and Handling of Lafarge Plasterboard

1. Lafarge Plasterboard should be stacked flat in a dry and smooth area to avoid ground dampness.
2. Use wooden bearers as supports.
3. 6,4mm board = 50 / stack
9mm board = 80 / stack
12mm standard = 2,7m = 60
= 3,3m = 60
= 3,6m = 60
15mm standard = 40
15mm board (FC + MR) = 40
4. No more than 5 stacks should be piled over one another. The bearers of each stack must be aligned.
5. The Lafarge Plasterboards should be kept indoors. If outside storage is temporarily required, cover the Lafarge Plasterboards with plastic or waterproof canvas.
6. Lafarge Plasterboard should be carried on its edges in an upright position by two people, rather than flat. 1 to 2 Lafarge Plasterboards can be carried at a time.



Partition Installation Using a Lafarge Ridgeback Steel Stud and Track

1. Install the galvanised steel stud by laying floor tracks horizontally on floor and ceiling and fix in place.
2. Insert studs vertically in tracks and leave space between each stud at 400 or 600mm intervals. The studs are held in place by friction.
3. Attach 12mm tapered-edge Lafarge Plasterboard steel studs by driving the 25mm Drywall screw into it. The space between each screw should not exceed 220mm.
4. Conceal the joint corner and screw dimple with Lafarge Jointing Plaster. Allow for setting time, then smooth.

Installation of Lafarge Firecheck Plasterboard

For use in office partitioning, residential internal walling, shopping centres, hotels, hospitals, schools and the like, a 2 hour fire rating or a safe/secure wall is required.

2 Hour Fire Rated Partition

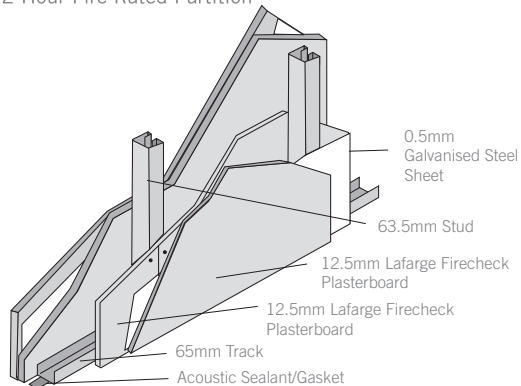

Application Details:

- Set 63.5mm studs spaced at 600mm intervals into 65mm track at floor and ceiling.
- Apply a base layer of 12.5mm Lafarge Extra Fire Resistant Plasterboard vertically to each side using 25mm Drywall Screws spaced at 220mm intervals.
- Fix a layer of 0.5mm galvanised steel sheeting using 25mm drywall screws.
- Apply the face layer of 12.5mm Lafarge Extra Fire Resistant Plasterboard vertically to each side using 41mm Drywall Screws spaced at 220mm intervals.
- Use Fibatape and Lafarge Jointing Plaster over the joints.
- All joints are to be staggered.
- Acoustic enhancement requires sealing between track, floor, ceiling and any other abutment joints.



LAFARGE PLASTERBOARD INSTALLATION TIPS

PARTITION:

1. The length of screw for fixing Lafarge Plasterboard to metal stud is equal to the thickness of Lafarge Plasterboard plus 10mm.
2. If the length of the partition is more than 15m, at every 15m interval an expansion joint must be used in order to prevent cracking.
3. Always leave about 10mm space from the floor to prevent dampness from creeping up the Plasterboard.
4. In high humidity areas, use the Lafarge Moisture Check Plasterboard.

CURVED SURFACE INSTALLATION OF PARTITIONS

Lafarge Plasterboard can be curved into many forms to fit various desired interior wall and ceiling designs.

Framing Installation:

The horizontal steel track can be prepared in 2 ways, using either the internal or external arc web cuts.

1. Cut one leg and web of top and bottom steel stud at 50mm intervals for the length of the arc. Leave about 400mm of uncut steel studs at end of arc.
2. Bend tracks either as A or B to form curve of desired radius (90mm max arc).
3. Attach the steel track to structural elements at floor and ceiling. Position vertical studs, with open side facing the same direction and engaging floor and steel studs.

Curved Surface Installation

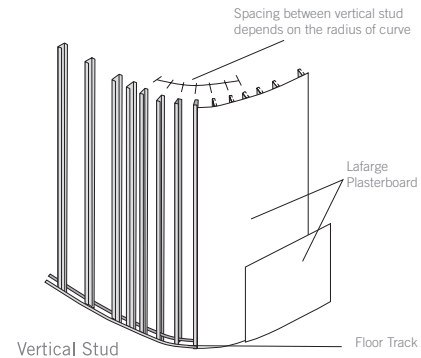
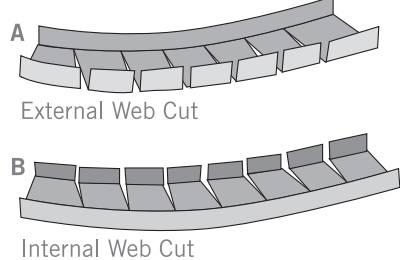

Apply sufficient Lafarge Jointing Plaster over the screw head to achieve a smooth surface. Allow 30 minutes for the plaster to set. Apply the second coat (if required) and leave it for 2 hours. Smooth with sand paper.

EXTERNAL CORNER CONCEALING FOR PARTITIONS

A corner bead is used for reinforcing the corner of a Lafarge Plasterboard partition.

1. Cut the corner bead to the same length as the partition height.
2. Attach it to both sides of the corner.
3. Fix 25mm Drywall Screws along the corner bead at every 100mm interval on both sides.
4. Conceal both sides of the corner bead with Lafarge Jointing Plaster approximately 3mm thick. Leave for 70 minutes to set.
5. Apply the second coating about 300mm wide from the corner edge.
6. Allow 24 hours after second coating, smooth with 80 grit sandpaper.

CUTTING LAFARGE PLASTERBOARD

Lafarge Plasterboard has a unique snap-effect which allows for easy cutting of the board and can be cut by using two methods.

Using a sharp cutter

1. Draw a line on the board.
2. Cut the board by first scoring on the face side through the paper to the core (a straight edge helps).
3. The board is then snapped back away from the cut face.
4. The back paper can be broken by snapping the board in the opposite direction, or by scoring with a utility knife.
5. Sand all cut edges.

Using a saw

1. Draw a line on the board.
2. Saw the board by a fine tooth saw.
3. Sand all cut edges.

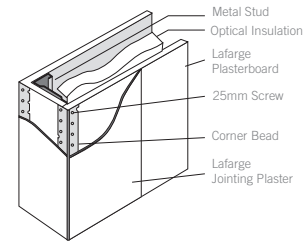

External Corner Fair End Concealing

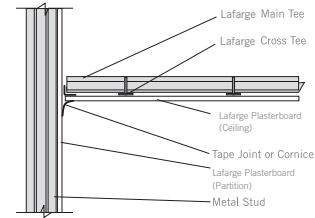

Finished joint between wall and ceiling



Snap Lafarge Plasterboard and cut other side of paper

JOINT CONCEALING

There are three steps to concealing joints:

1. Centre the Fiba-tape on the joint and press it down with the scraper to ensure the Fiba-tape adheres firmly.
2. Apply a coat of Lafarge Jointing Plaster onto the Fiba-tape using a scraper to even the surface and to ensure the plaster flows into the Fiba-tape. Allow 70 minutes to set.
3. Clean the joint surface with the edge of a trowel and apply the second coat. Allow 24 hours for the plaster to dry thoroughly. Smooth the joint by sanding to achieve a monolithic surface.

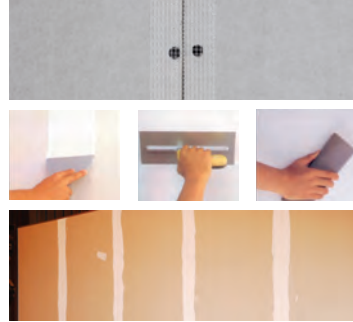

DEPTH OF DRYWALL SCREWS

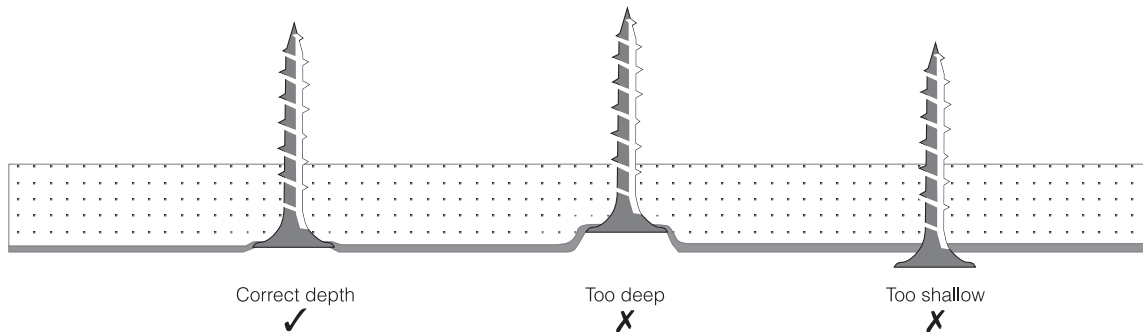



LAFARGE FIXED PARTITION

Lafarge Drywall is a lightweight non-demountable partition system which has no visible joints on completion. The internal framework consists of standard Ridgeback Stud and Drywall Track profiles manufactured from galvanised steel. Tapered edge plasterboards are screw fixed to the studs allowing for plaster jointing. Paint or wallpaper finishes can then be applied for a joint free wall of subtle quality.

Attractive Slimline Glazing Mullions and transoms can be created by clip fixing the required aluminium male section onto its four-legged female partner which has already been fixed into position.

Door Frame Kits are supplied premitred and with optional lock cutouts. Full height Door Frames clip directly onto the Aluminium Female ceiling trim by means of the Male Aluminium Door header. Standard door frame kits have both styles and header manufactured from four-legged Female Aluminium Door Frame sections. It is recommended that for additional stability when erecting full height doors, the Ridgeback Stud should be boxed onto the open side of a Floor Track prior to fixing (the Female Door Frame Section).

The four-legged Female partition solutions Aluminium Door Frame, Glazing and Termination Sections are positively fixed to the galvanised steel Ridgeback Studs by means of pop rivets or screws. This ensures sturdy framing for the Plasterboards and strong support for the clip-on Male Aluminium sections.

The Aluminium Glazing Bead which carries a neat Bubble Seal Gasket (or optional woolpile) easily clips into place after the glass has been positioned, leaving an attractive Aluminium shopfront type finish, having slim and clean lines. The Bubble Seal Gasket will accommodate glass thickness from 4mm to 6mm. (nominal thickness).

Fire rating: Lafarge Drywall (89mm partition) has a 30 minute fire rating as per SABS 0177: Parts-2005. For further details as well as information on 60 minutes plus fire ratings please consult with our technical staff.

All Lafarge Aluminium sections may be Powder Coated or Anodised to complement the decorated finish of the boards. Aluminium Skirting or recessed base can be similarly treated to match or contrast as required.

COMPONENTS

CONNECTING LAFARGE PARTITION SOLUTIONS

Ridgeback Stud



51mm for 76mm partition
64mm for 89mm partition
58mm for 89mm partition
102mm for 126mm partition
102mm for 132mm partition

Drywall Track

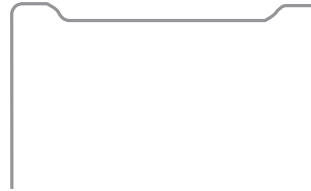

51mm track
58mm track
64mm track
102mm track

Lafarge Aluminium Framing

The Lafarge Drywall System consists of Male and Female Aluminium extrusions.

- Female Sections support and position the Lafarge Plasterboard as in conventional drywalling.
- Male Sections are clip fixed to the Female Sections to form Glazing Mullions and Transoms, Door frame to Glazing details and to facilitate full height Glazing and full height doors. Bubble Seal Gasket (which is used for both Door frame and Glazing Sections) is to be inserted before constructing the frames.

FEMALE ALUMINIUM SECTIONS

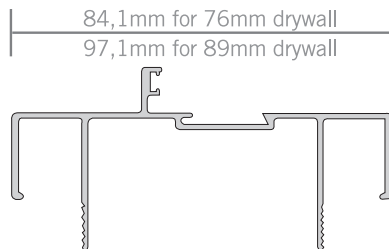

15mm
19,5 mm

MALE ALUMINIUM SECTIONS

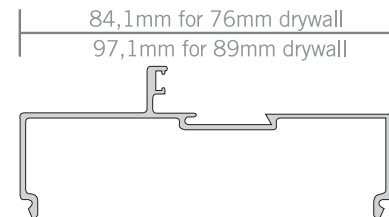

FEMALE ALUMINIUM SECTIONS

Glazing Section
Die 6668 for 76mm (12mm board)
Die 6679 for 89mm (12mm board)
Die 6677 for 89mm (15mm board)

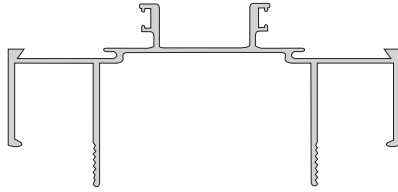

15 mm
21 mm

Double Glazing Section
Die 6680 for 76mm
Die 6676 for 89mm

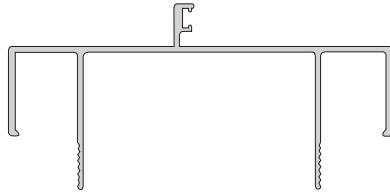

10 mm
19,5 mm

MALE ALUMINIUM SECTIONS

Glazing Section
Die 6667 for 76mm
Die 6678 for 89mm

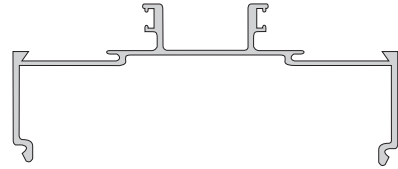

Double Glazing Section
Die 6681 for 76mm
Die 6682 for 89mm

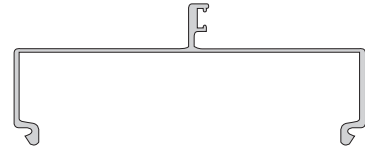

FEMALE ALUMINIUM SECTIONS

Door frame
 Die 6059 for 76mm (12mm board)
 Die 6159 for 89mm (12mm board)
 Die 6633 for 89mm (15mm board)

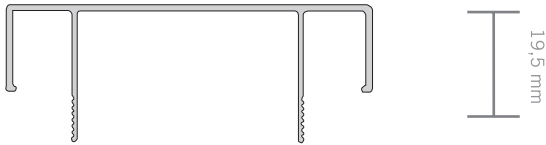

Termination
 - head channel
 - wall channel

Die 6060 for 76mm (12mm board)
 Die 6160 for 89mm (12mm board)
 Die 6632 for 89mm (15mm board)

MALE ALUMINIUM SECTIONS

Door frame
 Die 6163 for 76mm
 Die 6164 for 89mm
 (header for full height doors only)



Termination
 Die 6056 for 76mm
 Die 6161 for 89mm

ALTERNATIVE ALUMINIUM

ALTERNATIVE ALUMINIUM HEAD AND BASE SETS

Female Recessed Head
 Die 6165 for 76mm / Die 6166 for 89mm

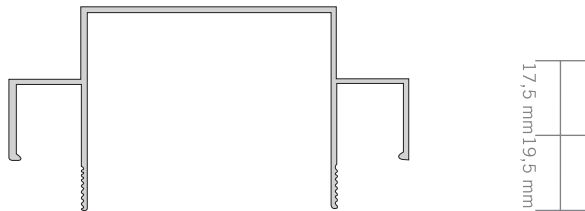

54 mm for 76mm drywall
 67 mm for 89mm drywall

Female Recessed Base
 Die 6206 for 76mm / Die 6207 for 89mm

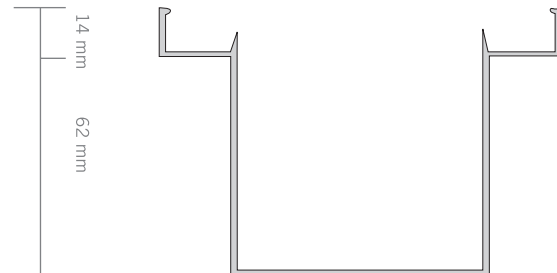

54 mm for 76mm drywall
 67 mm for 89mm drywall

ALTERNATIVE ALUMINIUM SECTIONS

ALTERNATIVE ALUMINIUM HEAD AND BASE SETS

Female Recessed Head
Die 6165 for 76mm / Die 6166 for 89mm

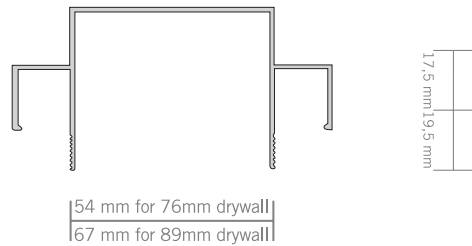

Female Recessed Base
Die 6206 for 76mm / Die 6207 for 89mm

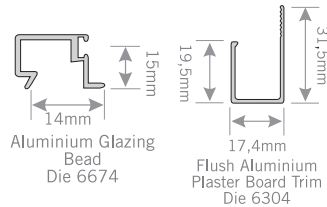
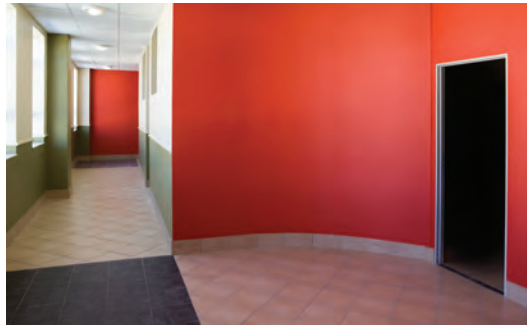
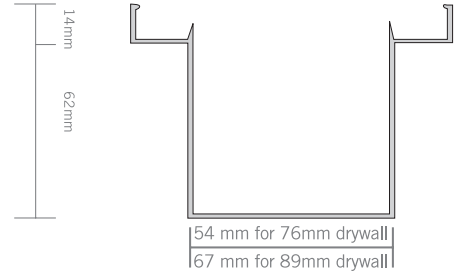

12mm
Plasterboard Trim
Die 6638

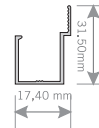

15mm
Plasterboard Trim
Die 6637

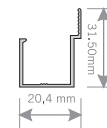

MXG Bubble Seal Gasket
(grey or black)

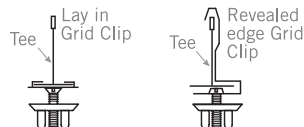

Traditional Door Frame
Die 6507

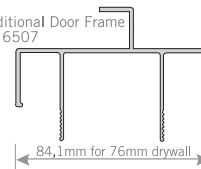

Traditional Door Frame
Die 6508

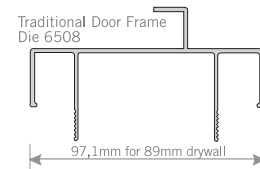

DOUBLE GLAZING/INTEGRAL BLINDS

89mm Drywall System

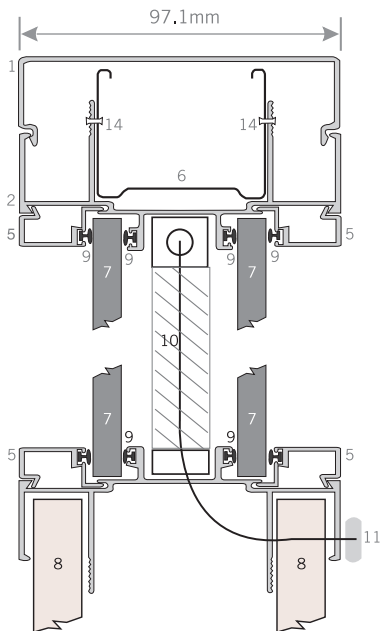
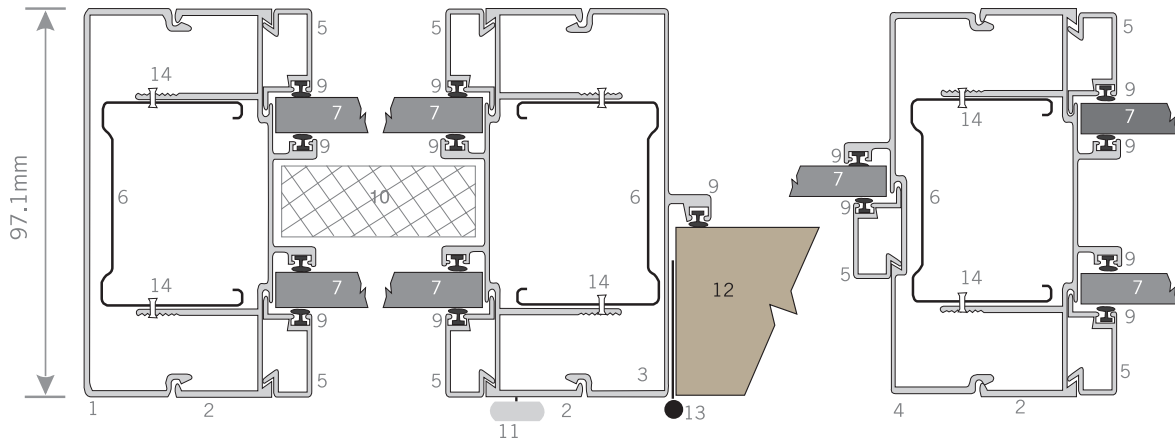

1. Aluminium Male Termination Section Die 6161
2. Aluminium 4 Leg Female Double Glazing Section Die 6201
3. Aluminium Male Door Frame Section Die 6164
4. Aluminium Male Glazing Section Die 6672
5. Aluminium Glazing Bead Die 6674
6. Ridgeback Stud (64mm)
7. 4-6mm Glass
8. Lafarge Plasterboard
9. Bubble Seal Gasket
10. Blinds
11. Blinds Mechanism Showing Cable
12. 40mm Door
13. Aluminium Sinkless Hinge
14. Pop Rivets



LAFARGE FIXED PARTITION

ALUMINIUM DOORS

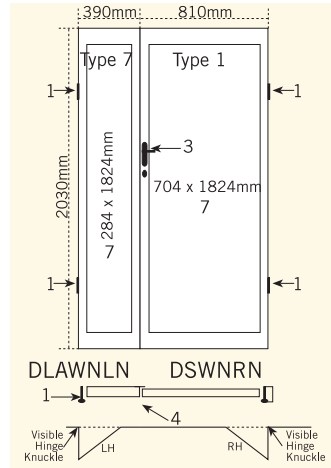
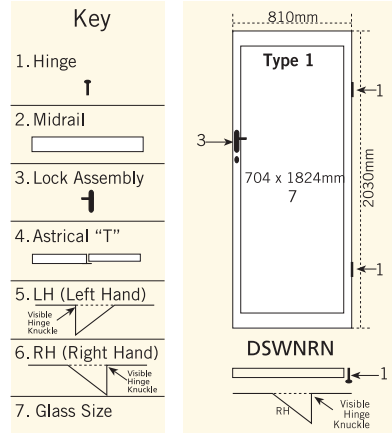

ALTERNATIVE ALUMINIUM

ALUMINIUM DOORS

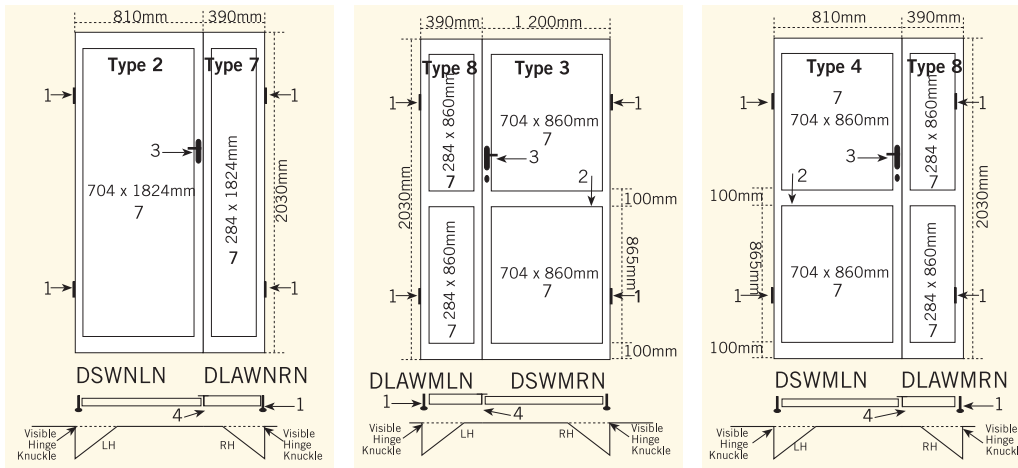
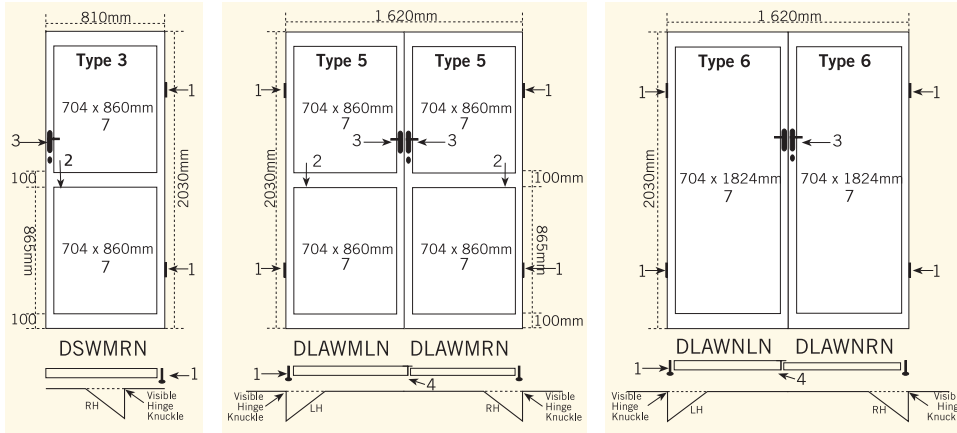

LAFARGE FIXED PARTITION

CONSTRUCTION DETAILS

1 Drywall Joint

- 1 Lafarge Ridgeback Stud
- 2 Lafarge Plasterboard (tapered edge)
- 3 Drywall Screws
- 4 Skimmed joint

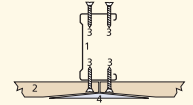

2 Wall Starter/Termination/Ceiling Junction (alternative fig 4)

- 1 Aluminium 4 Leg Female Termination Die 6060/6160
- 2 Lafarge Plasterboard
- 3 Drywall Screws
- 4 Aluminium Termination (alternative) Ceiling and Wall Channel Die 6204/6205
- 5 Drywall Track
- 6 Fixing (mechanical/velcro/ grip clip)

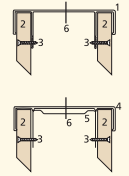

3 Standard Base

- 1 Aluminium Ribbed Skirting Die 6144
- 2 Lafarge Plasterboard
- 3 Lafarge Ridgeback Stud
- 4 Drywall Track
- 5 Skirting Screws

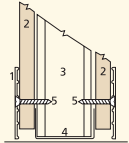

4 Recessed Head (alternative to fig 2)

- 1 Aluminium Recessed Head Die 6165/6166
- 2 Lafarge Ridgeback Stud
- 3 Lafarge Plasterboard
- 4 Ceiling Tile
- 5 Fixing (mechanical/velcro/grip clip)
- 6 Drywall Screws

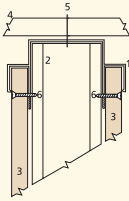

5 Glazing Mullion

- 1 Aluminium 4 Leg Female Glazing Die 6668/6679
- 2 Aluminium Glazing Bead
- 3 Lafarge Ridgeback Stud
- 4 Lafarge Plasterboard
- 5 4-6mm Glass
- 6 Drywall Screws
- 7 Bubble Seal Gasket

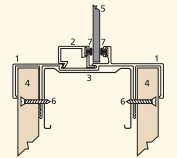

6 Door Frame

- 1 Aluminium 4 Leg Female Glazing Die 6059/6159
- 2 Lafarge Ridgeback Stud Die 6674
- 3 Lafarge Plasterboard
- 4 Door (40mm)
- 5 Drywall Screws
- 6 Bubble Seal Gasket
- 7 Drywall Track (optional for additional stability for full height/solid doors and swing doors).
- 8 Aluminium Sinkless Hinge

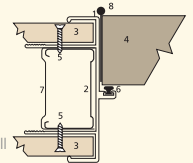

LAFARGE FIXED PARTITION

CONSTRUCTION DETAILS

6 Door Frame/Glazing Mullion

- 1 Aluminium 4 Leg Female Doorframe
- 2 Lafarge Ridgeback Stud
- 3 Aluminium Male Glazing Section Die 6667/6678
- 4 Aluminium Glazing Bead Die 6674
- 5 4 - 6 mm Glass
- 6 Door (40 mm)
- 7 Pop Rivets
- 8 Bubble Seal Gasket

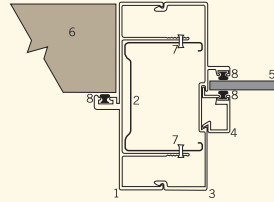

7 Glazing Mullion or Transom

- 1 Aluminium 4 Leg Female Section Die 6668/6679
- 2 Lafarge Ridgeback Stud
- 3 Aluminium Male Glazing Section Die 6667/6678
- 4 Aluminium Glazing Bead Die 6674 with Bubble Seal Gasket
- 5 4 - 6 mm Glass
- 6 Pop Rivets
- 7 Bubble Seal Gasket

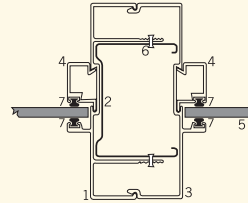

8 Door frame with Corner and Glazing

- 1 Aluminium 4 Leg Female Door frame Die 6059/6159
- 2 Aluminium 4 Leg Female Section Die 6668/6679
- 3 Aluminium Glazing Bead Die 6036
- 4 Lafarge Ridgeback Stud
- 5 Lafarge Plasterboard
- 6 Door (40 mm)
- 7 4-6mm Glass
- 8 Drywall Corner Bead
- 9 Dry Wall Screws
- 10 Bubble Seal Gasket
- 11 Skimmed Corner

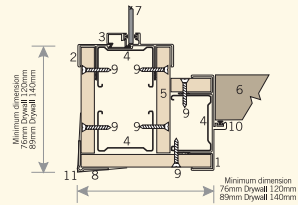

9 Standard Corner

- 1 Lafarge Ridgeback Stud
- 2 Drywall Corner Bead
- 3 Lafarge Plasterboard
- 4 Drywall Screws
- 5 Skimmed Corner

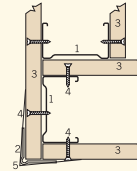

10 Recessed Base

- (alternative to fig 3)
- 1 Aluminium recessed Base Die 6206/6207
 - 2 Lafarge Ridgeback Stud
 - 3 Lafarge Plasterboard
 - 4 Drywall Screws

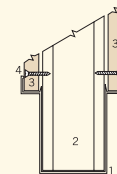

11 Dry Lining Detail Utilising Plasterboard Trim

- 1 Plasterboard Trim Die 6304
- 2 Lafarge Plasterboard
- 3 Lafarge Ridgeback Stud
- 4 Drywall Track
- 5 40mm Drywall Screws
- 6 5mm Drywall Screws

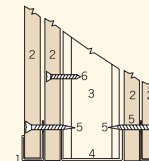

POWER SKIRTING DETAILS

Two sections of WALL MOUNTED Power Skirting placed back to back to achieve double volume Power Skirting.

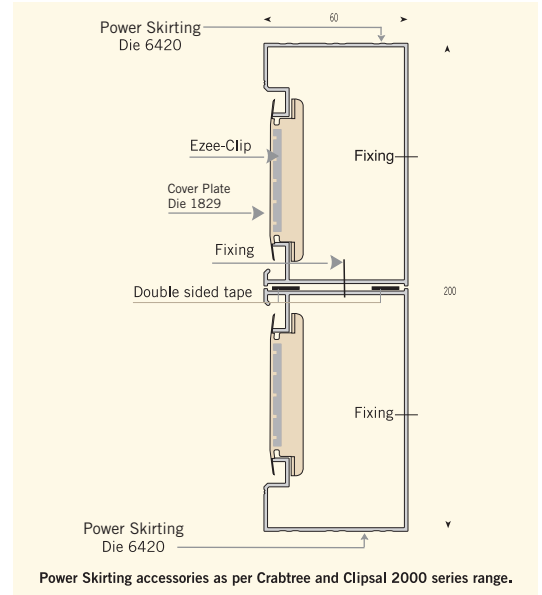

TYPICAL CONSTRUCTION DETAILS

1. Wall Starter/Termination/Ceiling Junction

- 1 Aluminium 4 Leg Female Termination Die 6632
- 2 Lafarge Plasterboard
- 3 Drywall Screws
- 4 Aluminium Termination (alternative) Ceiling and Wall Channel Die 6204/6205
- 5 Drywall Track 59mm
- 6 Fixing (mechanical/velcro/grid clip)

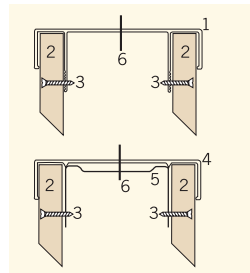

2. Glazing Mullion

- 1 Aluminium 4 Leg Female Glazing Die 6677
- 2 Aluminium Glazing Bead Die 6635
- 3 Lafarge Ridgeback Stud 58mm
- 4 Lafarge Plasterboard
- 5 4 - 6 mm Glass
- 6 Drywall Screws
- 7 Bubble Seal Gasket

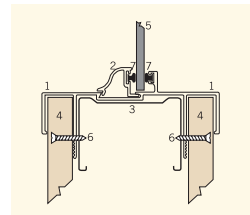

LAFARGE FIXED PARTITION

TYPICAL CONSTRUCTION DETAILS

3. FOR 15MM LAFARGE PLASTERBOARD

Door Frame

- 1 Aluminium 4 Leg Female Door frame Die 6633
- 2 Lafarge Ridgeback Stud
- 3 Lafarge Plasterboard
- 4 Door (40 mm)
- 5 Drywall Screws
- 6 Bubble Seal Gasket
- 7 Aluminium Sinkless Hinge

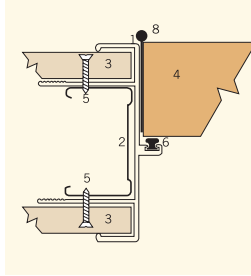

4. Door Frame (Full Height, Solid and Swing Doors)

- 1 Aluminium 4 Leg Female Door Frame Die 6633
- 2 Lafarge Ridgeback Stud 58mm
- 3 Lafarge Plasterboard
- 4 Door (40 mm)
- 5 Drywall Screws
- 6 Bubble Seal Gasket
- 7 Drywall Track 59mm (optional stability for full height/solid doors/swing doors)
- 8 Aluminium Sinkless Hinge

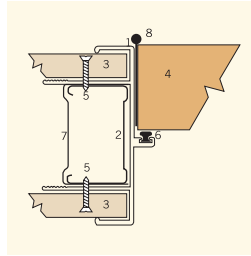

FIRE RATING ON SYSTEM AVAILABLE

Specifications: Lafarge Fixed Partitions: 76mm

Supply and install Lafarge Fixed Partition from Lafarge Gypsum, drywall partitioning system with an overall thickness of 76mm comprising internal framing formed of 51mm Lafarge galvanised steel studs fixed at 600mm centres to Lafarge galvanised steel track/aluminium female head section and Lafarge galvanised steel floor track, where necessary, any additional galvanised steel studding to form door openings, glazing and other apertures, angles and corners and terminated ends. The internal steel framing is to be dressed on both sides with 12mm thick Lafarge tapered edge plasterboards in single lengths to suit height, butt jointed and secured to a steel studding with 25mm drywall screws at a maximum 220mm centres. Joints are to be tapped and jointed with Lafarge Jointing Compound and prepared for painting or wall-papering. All external aluminium door frames, glazing frames, ceiling and wall channels and skirting are to be formed of natural anodised/colour anodised/powder coated to specific colour.

Maximum height 3 600mm.

Installation to be in accordance with SABISA (South African Building Interior Systems Association) installation guidelines.

Specification: Lafarge Fixed Partition: 89mm

Supply and install Lafarge Fixed Partition from Lafarge Gypsum, drywall partitioning system with an overall thickness of 89mm comprising internal framing formed of 64mm Lafarge galvanised steel studs fixed at 600mm centres to Lafarge galvanised steel track/aluminium female head section and galvanised steel floor track, where necessary, any additional galvanised steel studding to form door openings, glazing and other apertures, angles and corners and terminated ends. The internal steel framing is to be dressed on both sides with 12mm thick Lafarge tapered edge plasterboards in single lengths to suit height, butt jointed and secured to a steel studding with 25mm drywall screws at a maximum 220mm centres. Joints are to be tapped and jointed with Lafarge Jointing Compound and prepared for painting or wall-papering. All external aluminium door frames, glazing frames, ceiling and wall channels and skirting are to be formed of natural anodised/colour anodised/powder coated to specific colour.

Maximum height 3 600mm.

Installation to be in accordance with SABISA (South African Building Interior Systems Association) installation guidelines.

LAFARGE FIXED PARTITION SPECIFICATIONS AND DETAILS

Lafarge Fixed Partition Specification

Lafarge Fixed Partition is a lightweight walling system which has no visible joints on completion. The internal framework consists of standard Lafarge Ridgeback stud and Lafarge Fixed Track profiles manufactured from galvanised steel.

Tapered edge Lafarge Plasterboards are screw fixed to the studs allowing for plaster jointing. Paint or wall paper finishes can then be applied for a joint free wall of subtle quality. This ensures sturdy framing for the Lafarge Plasterboards.

Fire rating: Lafarge Residential (89mm partition) has a 30 minute fire rating as per SABS 0177: Parts 2005. For further details as well as information on 60 minutes plus fire ratings please consult with our technical department.

Components

Internal Framework

The internal framework shall consist of floor and ceiling track with vertical Lafarge Ridgeback Studs. The Lafarge Floor Track shall be firmly screwed or shot fixed to the floor. The top track (Galvanised), shall be fixed to the Lafarge ceiling grid or roof structure. When fixing to other solid surfaces the top track shall be mechanically screwed or shot fixed.

Door Frames

Aluminium door frames to fit 76mm/89mm partitions can be used. For fire rated drywall partitions, pre-made fire rated doors must be used. Custom made pressed steel or timber door frames can be used for non-standard drywalls.

Panels

Installation (See Figure 1 and 2)

Installation shall commence with the fixing of the track to the floor and the ceiling. Studs to be fixed to existing wall as a wall starter. The Lafarge Ridgeback Studs are then installed vertically at maximum 600mm centres. The 12mm -15mm thickness tapered edge Lafarge Plasterboard sare then held in place by means of 25mm drywall screws which are driven through the Lafarge Plasterboard and into the Lafarge Ridgeback Studs at a maximum spacing of 220mm between screws.

The Lafarge Plasterboards are held in place at the base by the skirting and fixed to the steel framework with 25mm drywall screws. Where the Lafarge Fixed Partition is being installed beneath a plastered ceiling, Lafarge Galvanised Drywall Track is fixed to the ceiling.

Jointing Lafarge Plasterboards tapered edge points to be finished with fiba-tape and jointing compound.

Wall Finishes

Walls should be primed with a suitable primer and then painted with a colour to suit.

Doors

All doors must comply with General Specification for Fixed Partitions.

General Guide Lines for Partitioning Systems and lightweight walls. Special attention should be given to the glazing and door details to ensure the compliance to the fire regulation, if required.

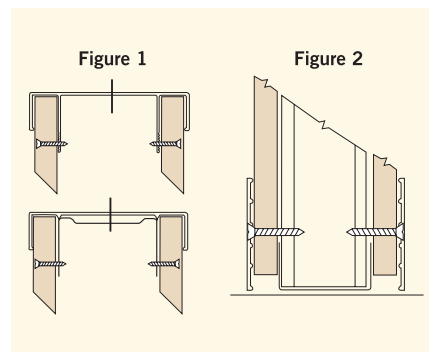

All Steel components of the Lafarge Partition System are manufactured by Lafarge Gypsum Reg No. 1997/08520 ISO9001 - 2008

LAFARGE FIRE RATED PARTITION SYSTEMS

LAFARGE GYPSUM DRYWALL INTERNAL PARTITION SYSTEM

LPS 51-0 /1

Non load bearing drywall system
12mm Standard Plasterboard-one layer each side

APPLICATION: Commercial

WALL PROPERTIES

51mm stud
Sound insulation reduction index - 36dB
Thickness - 76mm
Approximate weight - 20kg/m²

MATERIAL USED

- A - 51mm Drywall Lafarge steel stud
- B - 52mm Drywall Lafarge steel track
- C - 12mm Standard Tapered edge Plasterboard
- 25mm Drywall Screws
- Lafarge Drywall jointing system
- Floor and ceiling finishes as per specification

APPLICATION DETAIL

1. Set Lafarge steel studs spaced at 600mm c/c into steel track at floor and ceiling.
2. Apply a single layer of 12mm Lafarge Tapered edge plasterboard to each side side using 25mm drywall screws spaced at 220mm c/c.
3. Tape and joint according to specification.
4. Refer to standard specification.
5. Acoustic performance requires sealing between track, floor, ceiling and any other abutment joints.
6. Stagger the plasterboard joints in the system.

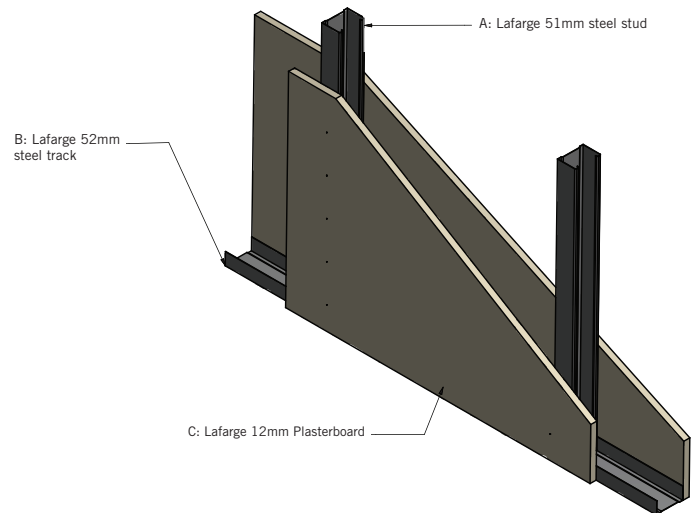
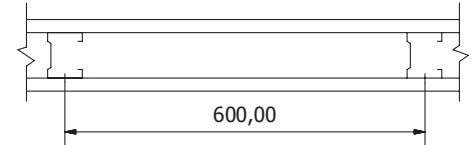

LAFARGE GYPSUM DRYWALL

LPS 58 -0/1

Non load bearing drywall system

15mm Technical Firecheck Plasterboard- one layer each side

APPLICATION: Commercial and Residential

WALL PROPERTIES

58mm stud

60 Min fire rating

Sound insulation reduction index - 40dB

Thickness - 88mm

Approximate weight - 23kg/m²

MATERIAL USED

- A - 58mm Drywall Lafarge steel stud
- B - 59mm Drywall Lafarge steel track
- C - 15mm Firecheck Tapered edge Plasterboard
- 25mm Drywall Screws
- Lafarge Drywall jointing system
- Floor and ceiling finishes as per specification

APPLICATION DETAIL

1. Set Lafarge steel studs spaced at 600mm c/c into steel at floor and ceiling.
2. Apply a single layer of 15mm Firecheck Taper edge plasterboard to each side using 25mm drywall screws spaced at 220mm c/c.
3. Tape and joint according to specification.
4. Refer to standard specification.
5. Acoustic performance requires sealing between track, floor, ceiling and any other abutment joints.
6. Stagger the plasterboard joints in the system.

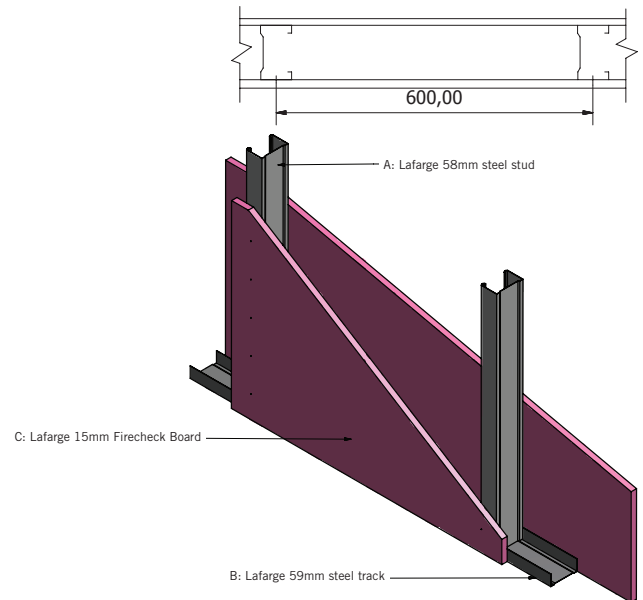

LAFARGE FIRE RATED PARTITION SYSTEMS

LAFARGE GYPSUM DRYWALL 30 MIN FIRE RATED INTERNAL PARTITION SYSTEM

LPF 64 - 30/1

Non load bearing drywall system
12mm Standard Plasterboard - one layer each side

APPLICATION: Commercial and Residential

WALL PROPERTIES

64mm stud
30 Min fire rating
Sound insulation reduction index - 38dB
Thickness - 89mm
Approximate weight - 21kg/m²

MATERIAL USED

- A - 64mm Drywall Lafarge steel stud
- B - 65mm Drywall Lafarge steel track
- C - 12mm Standard Tapered edge Plasterboard
 - 25mm Drywall Screws
 - Lafarge Drywall jointing system
 - Floor and ceiling finishes as per specification

APPLICATION DETAIL

1. Set Lafarge steel studs spaced at 600mm c/c into steel track at floor and ceiling.
2. Apply a single layer of 12mm Lafarge Tapered edge plasterboard to each side using 25mm drywall screws spaced at 220mm c/c.
3. Tape and joint according to specification.
4. Refer to standard specification.
5. Acoustic performance requires sealing between track, floor, ceiling and any other abutment joints.
6. Stagger the plasterboard joints in the system.

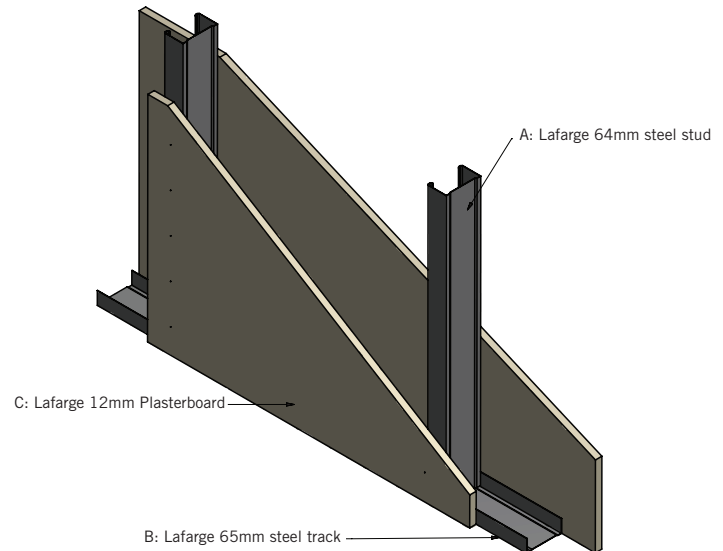
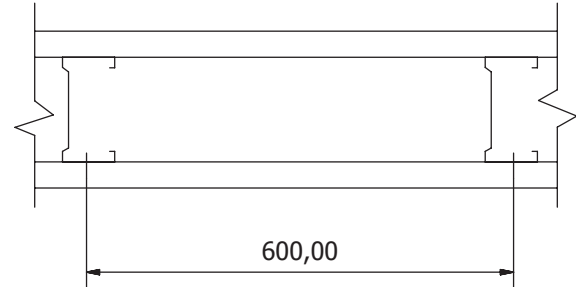

**LAFARGE GYPSUM DRYWALL
60 MIN FIRE RATED INTERNAL
PARTITION SYSTEM**

LPF 64 - 60/1

Non load bearing drywall system
15mm Technical Firecheck Plasterboard - one layer each side

APPLICATION: Commercial and Residential

WALL PROPERTIES

64mm stud
60 Min fire rating
Sound insulation reduction index - 40dB
Thickness - 94mm
Approximate weight - 23kg/m²

MATERIAL USED

- A - 64mm Drywall Lafarge steel stud
- B - 65mm Drywall Lafarge steel track
- C - 15mm Firecheck Plasterboard
- 25mm Drywall Screws
- Lafarge Drywall jointing system
- Floor and ceiling finishes as per specification

APPLICATION DETAIL

1. Set Lafarge steel studs spaced at 600mm c/c into steel track at floor and ceiling.
2. Apply a single layer of 15mm Firecheck Tapered edge plasterboard to each side using 25mm drywall screws spaced at 220mm c/c.
3. Tape and joint according to specification.
4. Refer to standard specification.
5. Acoustic performance requires sealing between track, floor, ceiling and any other abutment joints.
6. Stagger the plasterboard joints in the system.

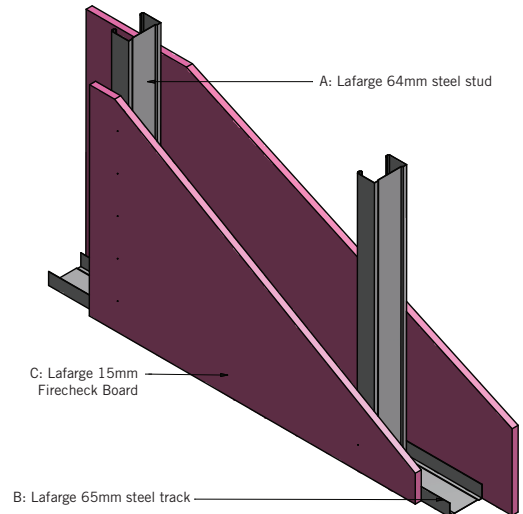
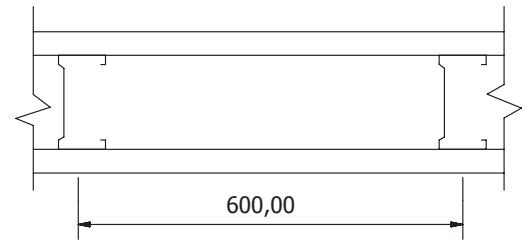

LAFARGE FIRE RATED PARTITION SYSTEMS

LAFARGE GYPSUM DRYWALL 60 MIN FIRE RATED INTERNAL PARTITION SYSTEM

LPF 64 - 60/2

Non load bearing drywall system
12mm Standard Plasterboard - double layer each side

APPLICATION: Commercial and Residential

WALL PROPERTIES

64mm stud
60 Min fire rating
Sound insulation reduction index - 45dB
Thickness - 112mm
Approximate weight - 39kg/m²

MATERIAL USED

- A - 64mm Drywall Lafarge steel stud
- B - 65mm Drywall Lafarge steel track
- C - 12mm Tapered Edge Plasterboard
 - 25mm Drywall Screws
 - Lafarge Drywall jointing system
 - Floor and ceiling finishes as per specification

APPLICATION DETAIL

1. Set Lafarge steel studs spaced at 600mm c/c into steel track at floor and ceiling.
2. Apply a single layer of 12mm standard plasterboard vertical to both sides using 25mm drywall screws spaced at 220mm c/c, stagger joints.
3. Apply a face layer of 12mm standard plasterboard to both sides staggering all joints, using 41mm drywall screws spaced at 220mm c/c.
4. Tape and joint according to specification.
5. Refer to standard specification.
6. Acoustic performance requires sealing between track, floor, ceiling and any other abutment joints.
7. Stagger the plasterboard joints in the system.

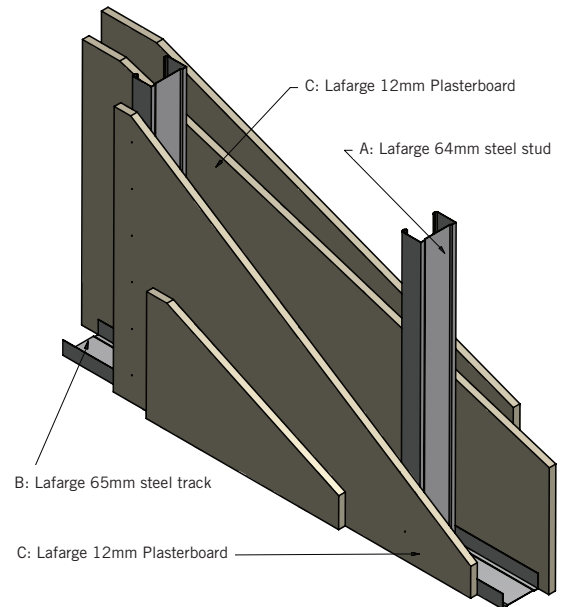
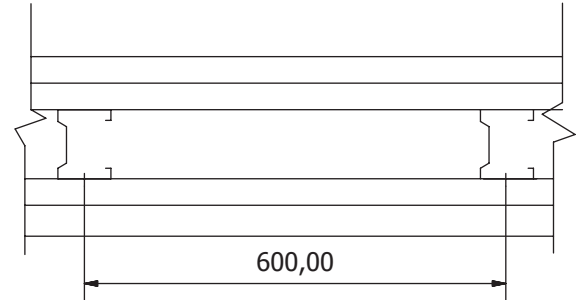

**LAFARGE GYPSUM DRYWALL
60 MIN FIRE RATING
INTERNAL PARTITION SYSTEM**

LPF 64 - 60/3

Non load bearing drywall system
12,5mm Technical Firecheck Plasterboard- one layer each side 80kg/m³
insulmatt wire mesh surface Fibre blanket

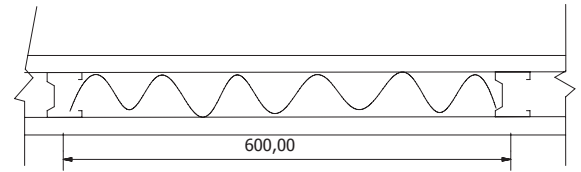

WALL PROPERTIES

64mm stud
60 Min fire rating
Sound reduction index with insulmatt wire mesh surfaced fibre blanket
80kg/m³ - 49dB
Thickness - 89mm
Approximate weight - 30kg/m²

MATERIAL USED

- A - 64mm Drywall Lafarge steel stud
- B - 65mm Drywall Lafarge steel track
- C - 12,5mm Firecheck Board
- 25mm Drywall Screws
- Lafarge Drywall jointing system
- Floor and ceiling finishes as per specif
- Insulmatt wire mesh surfaced fibre blanket of 80kg/m³

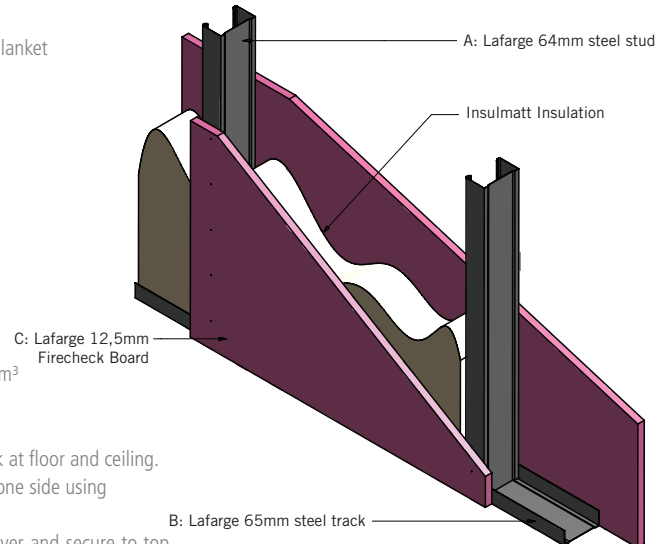

APPLICATION DETAIL

1. Set Lafarge steel studs spaced at 600mm c/c into steel track at floor and ceiling.
2. Apply a single layer of 12,5mm Firecheck Board vertical to one side using 25mm drywall screws spaced at 220mm c/c.
3. Position Insulmatt insulation between studs, fold the top over and secure to top track by positioning and fixing with galvanised angle.
4. Apply a single layer of 12,5mm Firecheck Board vertical to the other side using 25mm drywall screws spaced at 220mm c/c.
5. Tape and joint according to specification.
6. Refer to standard specification.
7. Acoustic performance requires sealing between track, floor, ceiling and any other abutment joints.
8. Stagger the plasterboard joints in the system.

LAFARGE FIRE RATED PARTITION SYSTEMS

LAFARGE GYPSUM DRYWALL 120 MIN FIRE RATED INTERNAL PARTITION SYSTEM

LPF 64 - 120/1

Non load bearing drywall system

12,5mm Technical Firecheck Plasterboard - 0,5mm galvanised steel between double layer of Technical Firecheck Plasterboard on each side.

WALL PROPERTIES

64mm stud

120 Min fire rating

Sound reduction index - 48dB

Thickness - 115mm

Approximate weight - 50kg/m²

MATERIAL USED

- A - 64mm Drywall Lafarge steel stud
- B - 65mm Drywall Lafarge steel track
- C - 12,5mm Taper Edge Technical Firecheck Board
- D - 0,5mm galvanised steel sheet
- 25mm and 41mm Drywall Screws
- Lafarge Drywall jointing system
- Floor and ceiling finishes as per specification

APPLICATION DETAIL

1. Set Lafarge steel studs spaced at 600mm c/c into steel at floor and ceiling.
2. Apply a single layer of 12,5mm tapered edge Firecheck Plasterboard vertical to one side using 25mm drywall screws spaced at 220mm c/c.
3. Apply 0,5mm galvanised steel sheet to each side (min 30mm overlap).
4. Apply a face layer of 12,5mm tapered edge Firecheck Plasterboard to both sides.
5. Tape and joint according to specification.
6. Refer to standard specification.
7. Acoustic performance requires sealing between track, floor, ceiling and any other abutment joints.
8. Stagger the plasterboard joints in the system.

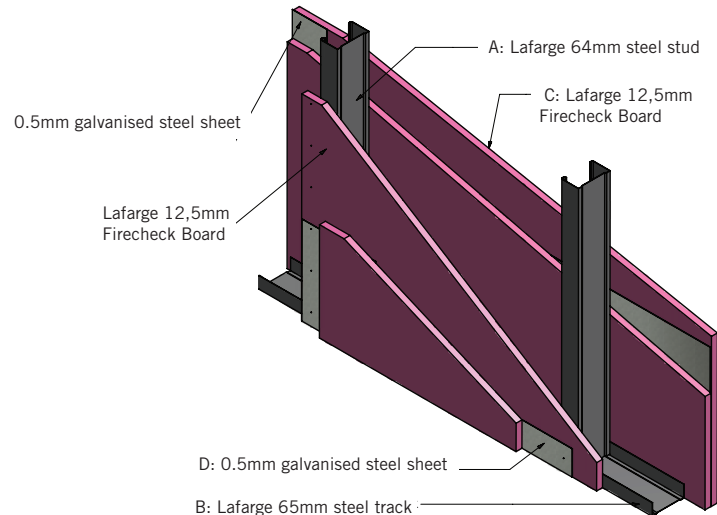
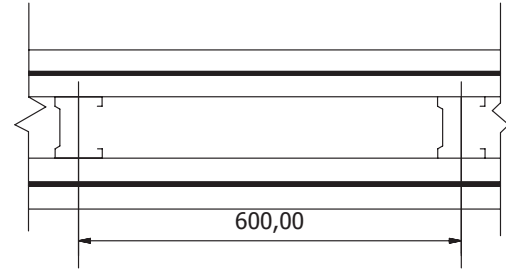

**LAFARGE GYPSUM DRYWALL
120 MIN FIRE RATED INTERNAL
PARTITION SYSTEM**

LPF 64 - 120/2

Non load bearing drywall system
15mm Technical Firecheck Plasterboard - double layer each side

WALL PROPERTIES

64mm stud
120 Min fire rating
Sound reduction index - 48dB
Thickness - 124mm
Approximate weight - 45.5kg/m²

MATERIAL USED

- A - 64mm Lafarge Drywall steel stud
- B - 65mm Lafarge Drywall steel track
- C - 15mm Firecheck tapered edge plasterboard
 - 25mm and 41mm Drywall Screws
 - Lafarge Drywall jointing system
 - Floor and ceiling finishes as per specification

APPLICATION DETAIL

1. Set Lafarge steel studs spaced at 600mm c/c into steel track at floor and ceiling.
2. Apply a single layer of 15mm Technical Firecheck Plasterboard vertical to both sides. using 25mm drywall screws spaced at 220mm c/c, stagger joints.
3. Apply a face layer of 15mm Technical Firecheck Plasterboard to both sides staggering all joints, using 41mm drywall screws spaced at 220mm c/c.
4. Tape and joint according to specification.
5. Refer to standard specification.
6. Acoustic performance requires sealing between track, floor, ceiling and any other abutment joints.
7. Stagger the plasterboard joints in the system.
8. Maximum partition height 4,5m.

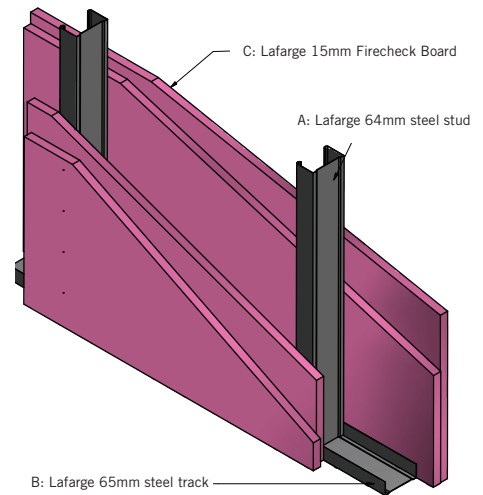
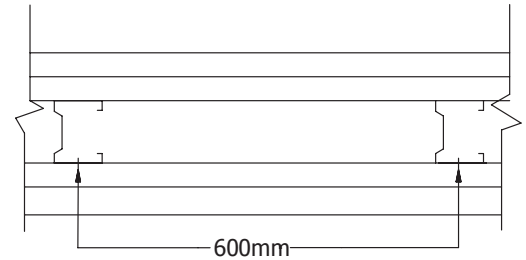

LAFARGE FIRE RATED PARTITION SYSTEMS

LAFARGE GYPSUM DRYWALL 60 MIN FIRE RATED INTERNAL PARTITION SYSTEM

LPF 102 - 60/1

Non load bearing drywall system
15mm Technical Firecheck Plasterboard - one layer each side

APPLICATION: Residential

WALL PROPERTIES

102mm stud
60 Min fire rating
Sound insulation reduction index - 40dB
Thickness - 132mm
Approximate weight - 24kg/m²

MATERIAL USED

- A - 102mm Lafarge Drywall steel stud
- B - 103mm Lafarge Drywall steel track
- C - 15mm Standard Tapered edge Plasterboard
- 25mm Drywall Screws
- Lafarge Drywall jointing system
- Floor and ceiling finishes as per specification

APPLICATION DETAIL

1. Set Lafarge steel studs spaced at 600mm c/c into steel track at floor and ceiling.
2. Apply a single layer of 15mm Firecheck Tapered edge plasterboard to each side using 25mm drywall screws spaced at 220mm c/c.
3. Tape and joint according to specification.
4. Refer to standard specification.
5. Acoustic performance requires sealing between track, floor, ceiling and any other abutment joints.
6. Stagger the plasterboard joints in the system.

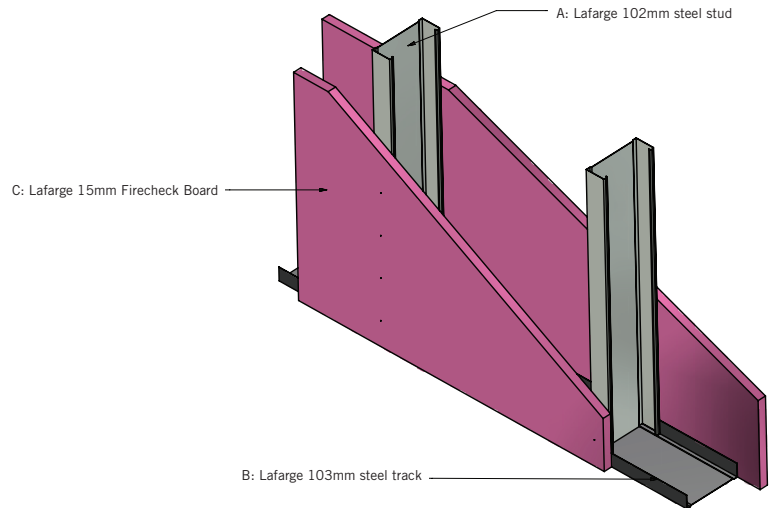
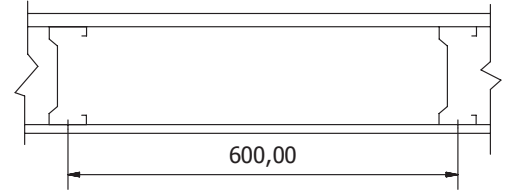

**LAFARGE GYPSUM DRYWALL
120 MIN FIRE RATED INTERNAL
PARTITION SYSTEM**

LPF 102 - 120/1

Non load bearing drywall system
15mm Technical Firecheck Plasterboard - Double layer each side

APPLICATION: Residential

WALL PROPERTIES

102mm stud
120 Min fire rating
Sound insulation reduction index - 50dB
Thickness - 162mm
Approximate weight - 46,5kg/m²

MATERIAL USED

- A - 102mm Drywall Lafarge steel stud
- B - 103mm Drywall Lafarge steel track
- C - 15mm Firecheck Tapered edge Plasterboard
 - 25mm and 41mm Drywall Screws
 - Lafarge Drywall jointing system
 - Floor and ceiling finishes as per specification

APPLICATION DETAIL

1. Set Lafarge steel studs spaced at 600mm c/c into steel track at floor and ceiling.
2. Apply a single layer of 15mm Technical Firecheck Plasterboard vertical to both sides using 25mm drywall screws spaced at 220mm c/c, stagger joints.
3. Apply a face layer of 15mm Technical Firecheck Plasterboard to both sides.
4. Tape and joint according to specification.
5. Refer to standard specification.
6. Acoustic performance requires sealing between track, floor, ceiling and any other abutment joints.
7. Stagger the plasterboard joints in the system.
8. Maximum Partition height 4,5m.

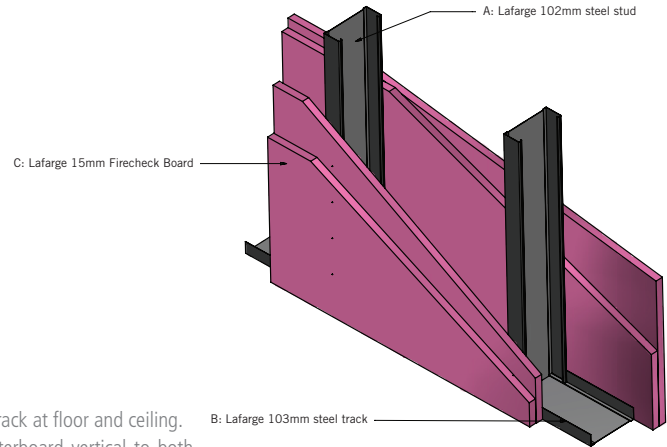
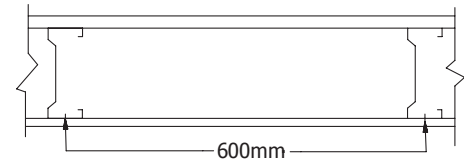



LAFARGE FINESSE[®] REMOUNTABLE PARTITION SYSTEM



TECHNICAL DETAILS

Introduction

The high quality Finesse® Aluminium components allow designers and space planners to combine full height and low level partitions using one system in the design of work stations.

The Lafarge Finesse® Remountable Partition System is designed for an ever-changing world where organisations constantly evaluate and improve their operations, and with them, their people and office environments.

The flexibility of the Lafarge Finesse® Remountable Partition System allows architects, designers, space planners and the like, to create working environments of varying styles and heights, based upon requirements for sound, fire-rating, privacy and space. The unique aluminium section design, incorporating the Finesse® clip fitting sections, eliminates the need for drilling and screwing in most applications.

Key Features

- Easy installation.
- Fully re-locatable in component form.
- Superb detailing and finishing.
- Comparative acoustic qualities.
- Pencil line, cover trims or flush wall appearance.
- Extensive variety of panel finishes.
- Centre, double or offset glazing.
- Integral blinds.
- Concealed fixed skirting.
- Curved and angular corner profiles.

- Strong substantial profiles.
- Manufactured to BS5750/ISO9002 Quality Standards.
- Integral wire management systems.
- Power Skirting 30 min SABS 0177: Part 2-2005.
- Full range of moulded capping pieces.

Planning

Finesse® offers unprecedented freedom in planning the optimum work place, freeing the designers from restraints placed upon them by other systems, while at the same time allowing the most efficient use of floor space.

The built-in flexibility of the Lafarge Finesse® Remountable System allows for easy adaptation or adjustment should this be required.

Wire Management

The Lafarge Finesse® Remountable Partition System is developed to accommodate the requirements of the most technologically advanced office environment. All electrical, data and communication cables can be placed within the spacious cavities provided by the framework, or alternatively in the designed power skirting situated at the base or at a preferred height within the Partition System.

Installation

The system must be installed by contractors who are trained and approved by Lafarge Gypsum (Pty) Ltd.



POSTS

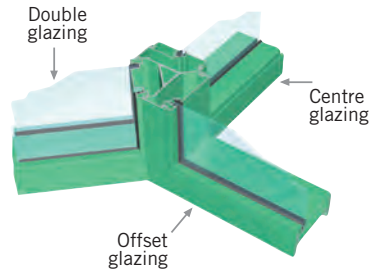

3 Way Y Post showing three different floor glazing details.

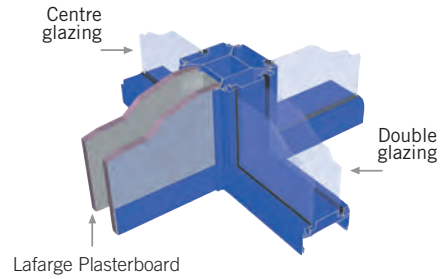

4 Way Box Post showing partition board and full height glazing details.

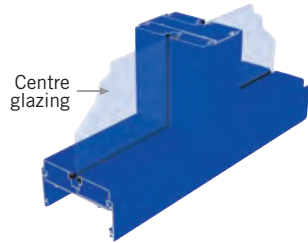

Main Post showing centre glazing details.

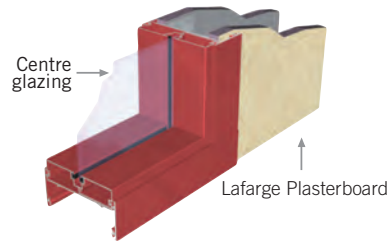

Main Post showing partition board and centre glazing details.

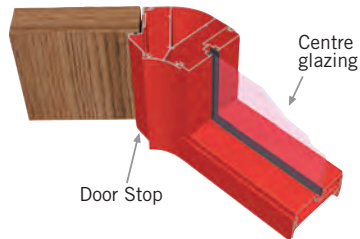

135V45Y corner post showing Door Stop and Centre Glazing details.



PRIMARY ALUMINIUM SECTIONS

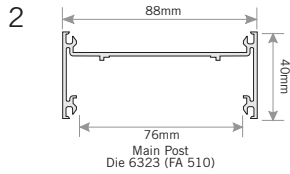
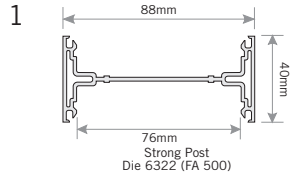

3 Skirting

Cover Trim
27mm Die 6314
40mm Die 6356 (FA685)



PVC Skirting Infill

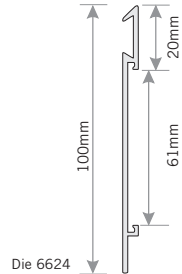

4 Terminations

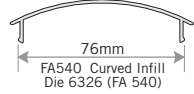
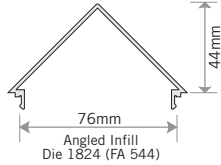
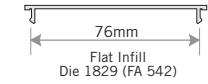

5 Door Stop

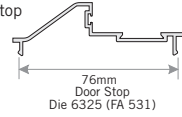

6 Glazing

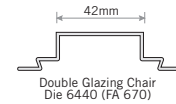
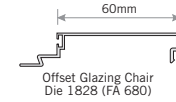
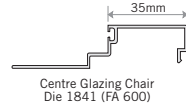
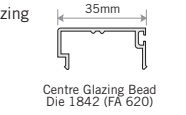

Sections not drawn to scale



ALUMINIUM ABUTMENTS

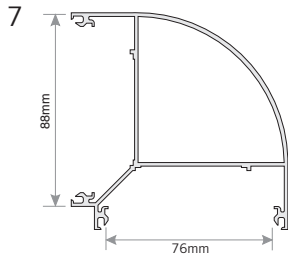

90° Corner Post
 Die 1825 (FA 560)

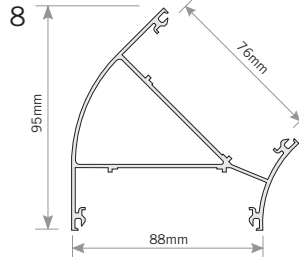

135° Corner Post
 Die 6324 (FA 550)

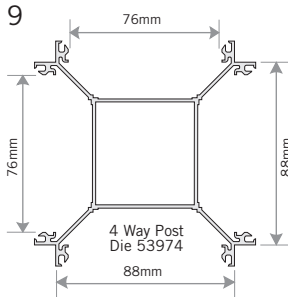

4 Way Post
 Die 53974

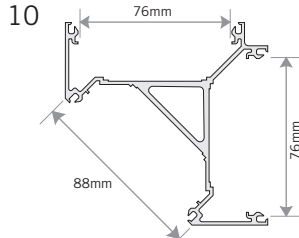

3 Way "Y" Post
 Die 6343 (FA 580)

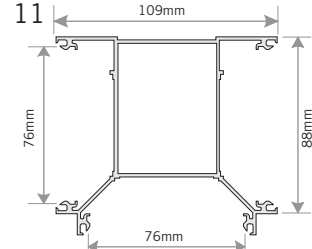

3 Way Box Post
 Die 6342 (FA 570)



COMPONENTS AND DIAGRAMS

A Dimension of track & stud in relation to board thickness

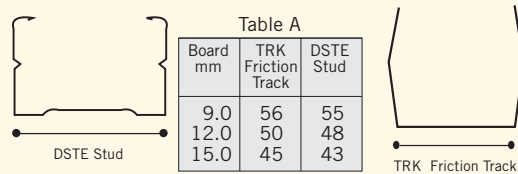

Board mm	TRK Friction Track	DSTE Stud
9.0	56	55
12.0	50	48
15.0	45	43

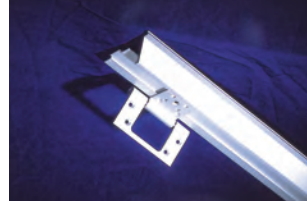

Finesse Hinge Located in Door Stop

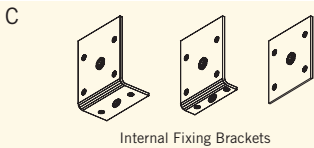
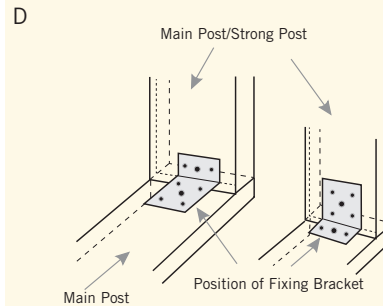
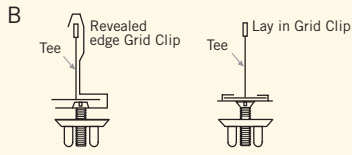

Internal Fixing Brackets

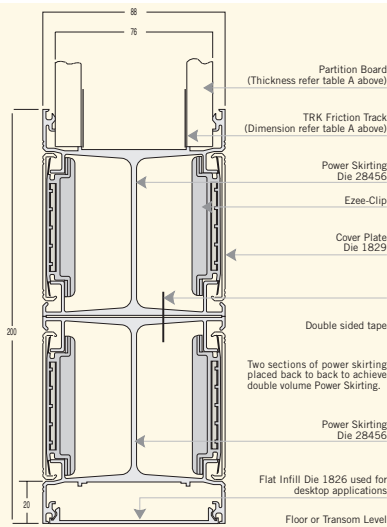

Power Skirting accessories as per Crabtree and Clipsal 2000 series range.

Finesse Lock Box



Rolled Galvanised Material
code FCL Clamping Strip

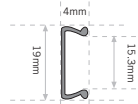

MXG Bubble Seal Gasket
(grey or black)

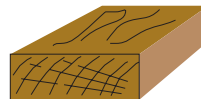

Timber Packers
(55mm x 24mm, 55mm x 16mm)

DETAILS

HEAD AND FLOOR DETAIL

1 Solid Head Detail Using Partition Board

1. Main Post Die 6323 (FA 510)
2. TRK Friction Track (Dimension refer table A Page 41)
3. DSTE Stud (Dimension refer table A Page 41)
4. Lafarge Plasterboard (Thickness refer table A Page 41)
5. Fixing (mechanical/grid clip)

Typical Detail Applies to Wall Abutments

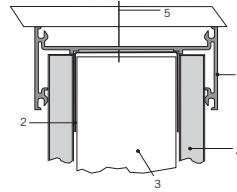

2 Solid Floor Detail Using Partition Board

1. TRK Friction Track (Dimension refer table A Page 41)
2. DSTE Stud (Dimension refer table A Page 41)
3. Lafarge Plasterboard (Thickness refer table A Page 41)
4. Fixing (mechanical/grid clip)
5. 40mm/75mm/100mm Skirting
6. Fixing (mechanical/velcro)

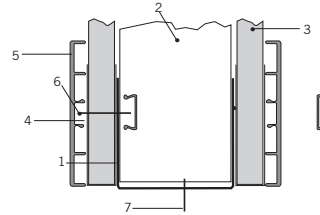

GLAZING DETAIL

3 Full Height Centre Glazing

1. Main Post Die 6323 (FA 510)
2. Centre Glazing Chair Die 1841 (FA 600)
3. Centre Glazing Bead Die 1842 (FA 620)
4. MXG Bubble Seal Gasket
5. 6mm Glass
6. Floor level

For Head Detail, Main Post fixed as Detail 1

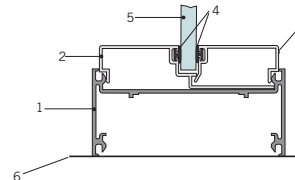

4 Solid to Offset Glazing

1. Main Post Die 6323 (FA 510)
2. Offset Glazing Chair Die 1828 (FA 680)
3. Outer Glazing Bead Die 6441 (FA 650)
4. MXG Bubble Seal Gasket
5. 4 - 6mm Glass
6. Lafarge Plasterboard (Thickness refer table A Page 41)
7. TRK Friction Track (Dimension refer table A Page 41)
8. DSTE Stud (Dimension refer table A Page 41)
9. Fixing

Typical Detail Applies to Wall Abutments

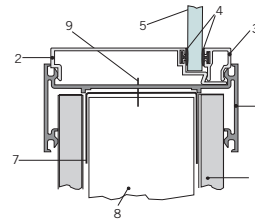

5 Solid to Double Glazing

1. Main Post Die 6323 (FA 510)
2. Double Glazing Chair Die 6327 (FA 670)
3. Outer Glazing Bead Die 6441 (FA 650)
4. MXG Bubble Seal Gasket
5. 4-6mm Glass
6. Lafarge Plasterboard (Thickness refer table A Page 41)
7. TRK Friction Track (Dimension refer table A Page 41)
8. DSTE Stud (Dimension refer table A Page 41)
9. Fixing

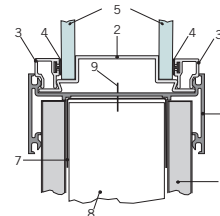

DETAILS

DOOR FRAME DETAIL

6 Full Height Door Head Detail

1. Main Post Die 6323 (FA 510)
2. Door Stop Die 6325 (FA 531)
3. MXG Bubble Seal Gasket
4. 40mm Door
5. Fixing

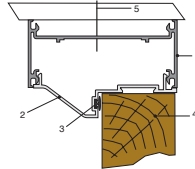

7 Door Head with Partition Board Above 5

1. Main Post Die 6323 (FA 510)
2. Door Stop Die 6325 (FA 531)
3. MXG Bubble Seal Gasket
4. 40mm Door
5. Lafarge Plasterboard (Thickness refer table A Page 41)
6. TRK Friction Track (Dimension refer table A Page 41)

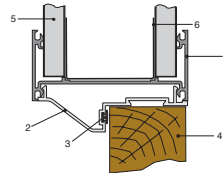

Note: Before fixing Main Post Door Transom cut and position Partition Board above

8 Door Mullion with Partition Board

1. Strong Post Die 6322 (FA 500)
2. Door Stop Die 6325 (FA 531)
3. MXG Bubble Seal Gasket
4. 40mm Door
5. Lafarge Plasterboard (Thickness refer table A Page 41)
6. TRK Friction Track (Dimension refer table A Page 41)
7. Timber Packer (55mm x 16 mm)
8. Fixing
9. Finesse Hinge

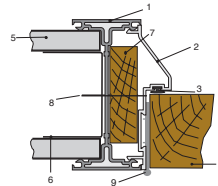

9 Door Mullion with Centre Glazing

1. Strong Post Die 6322 (FA 500)
2. Centre Glazing Chair Die 1841 (FA 600)
3. Centre Glazing Bead Die 1842 (FA 620)
4. MXG Bubble Seal Gasket
5. 4-6mm Glass
6. Door Stop Die 6325 (FA 531)
7. 40mm Door
8. Timber Packer (55mm x 16mm)
9. Fixing
10. Finesse Hinge

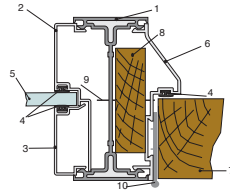

10 Board Joint Details

1. TRK Friction Track (Dimension refer table A Page 24)
2. DSTE Stud (Dimension refer table A Page24)
3. Lafarge Plasterboard (Thickness refer table A Page 24)
4. Clamping Strip
5. Die 6314 Cover Trim 27mm
6. Die 6356 Cover Trim 40mm (FA 685)
7. Fixing 1
8. Tapered edge Lafarge Partition Board
9. Tape and jointed

* NB Staggered joints improve noise reduction.

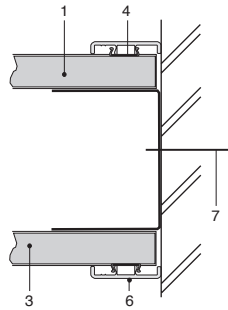

A) Wall abutment detail

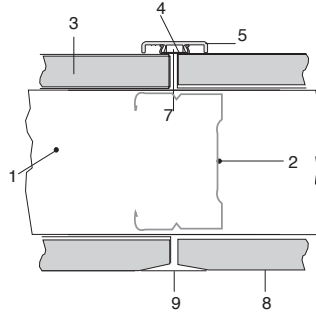

B) Jointing of boards

DETAILS

11 90° Corner Post Showing Clip on Door Stop and Board Detail

1. 90° Corner Post Die 1825 (FA 560)
2. Door Stop Die 6325 (FA 531)
3. MXG Bubble Seal Gasket
4. 40mm Door
5. Lafarge Plasterboard (Thickness refer table A Page 41)
6. TRK Friction Track (Dimension refer table A Page 41)
7. Fixing 69
8. Timber Packer (55mmx24mm)
9. Finesse Hinge 2

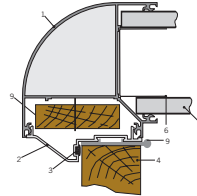

12 3 Way Box Post Showing Clip on Door Stop, Centre Glazing and Curved Infill Detail

1. 3 Way Boxed Post Die 6342 (FA 570)
2. Centre Glazing Chair Die 1841 (FA 600) 2
3. Centre Glazing Bead Die 1842 (FA 620)
4. MXG Bubble Seal Gasket 5
5. 4 - 6mm Glass 4
6. Door Stop Die 6325 (FA 531)
7. 40mm Door
8. Curved Infill Die 6326 (FA 540)

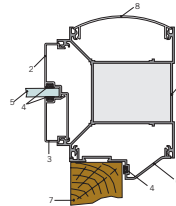

13 3 Way "Y" Post Showing Clip on Door Stop, Double Glazing and Flat Infill Detail

1. 3 Way "Y" Post Die 6343 (FA 580) 4
2. Offset Glazing Chair Die 1828 (FA 680)
3. Outer Glazing Bead Die 6441 (FA 650) 3
4. MXG Bubble Seal Gasket 4
5. Door Stop Die 6325 (FA 531) 7
6. 40mm Door
7. 4 - 6mm Glass
8. Flat Infill Die 1826 (FA 542)

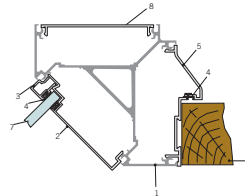

14 135°/45° Corner Detail Showing Clip on Door Stop and Board Details

1. 135°/45° Corner Post Die 6324 (FA 550)
2. Door Stop Die 6325 (FA 531)
3. MXG Bubble Seal Gasket
4. 40mm Door
5. Lafarge Plasterboard (Thickness refer table A Page 41)
6. TRK Friction Track (Dimension refer table A Page 41)
7. Finesse Hinge
8. Timber Packer (55mmx24mm)
9. Fixing

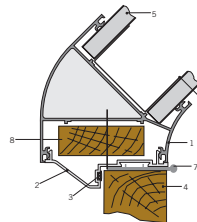

15 4 Way Box Post Showing Clip on Door Stop\Glazing\Angle Infill and Board Detail

1. 4 Way Boxed Post Die 53974
2. Centre Glazing Chair Die 1841 (FA 600)
3. Centre Glazing Bead Die 1842 (FA 620)
4. MXG Bubble Seal Gasket
5. 4 - 6mm Glass
6. Door Stop Die 6325 (FA 531)
7. 40mm Door
8. Lafarge Plasterboard (Thickness refer table A Page 41)
9. TRK Friction Track (Dimension refer table A Page 41)
10. Angled Infill Die 1824 (FA 544)

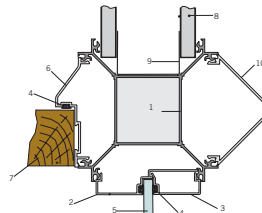

SPECIFICATIONS

All aluminium and steel components for the Lafarge Finesse® Remountable Partition System to be in accordance with components listed in diagrams 1 - 6 under Primary Aluminium Sections on Page 39, 7 - 11 under Aluminium Abutments on Page 40 and A - D under Components and Diagrams on Page 41 and shall be installed in strict accordance with the design specification and manufacturers instructions.

Installation Guide

Solid Partition

- Secure Main Post to ceiling, either by positive fix or using Ceiling Grid clips.
- Secure Main Post to vertical abutments, or alternative page 26 Fig 10a.
- At junction of horizontal and vertical Main Posts position, internal fixing bracket between nibs provided, align sections, and fix bracket to both sections through predrilled holes provided refer page 24 Fig. D, Internal Fixing Brackets. Wafertext or 3210 pop rivets can be used.
- Centrally between nibs provided in Main Posts fix the galvanised friction track.
- Plumb down position of galvanised Friction Track.
- Secure galvanised Friction Track to floor either by positive fix or use velcro on carpet/double sided tape on tiled floor.
- Position DSTE Stud vertically in the track at ceiling and floor, spaced at 600mm for 12mm board/400mm for 9,5mm Lafarge Plasterboard.
- Measure height from floor to ceiling, deduct 10mm, and cut partition board to size.
- When installing Lafarge Plasterboards:
 1. Locate partition board between Friction Track and Main Post slide up into position, or
 2. Position board against Friction Track, bow outwards, and locate between Friction Track and Main Post at head. Slide board into position at vertical aluminium sections.
- Ensure that a stud is always positioned centrally at vertical board joints.
- Secure Clamping Strip over board joint. (Clamping Strips must be saw cut to hold shape). Friction fix Aluminium Cover Trim onto Clamping Strip.
- To fix Clamping Strip for horizontal details, peel pop rivets are recommended. Friction fix Aluminium skirting/cover trim onto clamping strip.

- 100mm skirting to be fixed by drywall screw and PVC infill insert.
- It is recommended that Lafarge Plasterboards be covered prior to installation. This minimises on site work and mess, although plain Lafarge Plasterboards can be fitted for decoration in situ. Refer to Head and Floor Details Fig.1.2 page 24 / Board joint details page 25 Detail B.

Door Frames

Position Strong Posts vertically from floor to underside of Main Post, secure Main Post to floor with Internal Fixing Brackets, short leg of Internal Fixing Bracket to face door opening. Cut door Transom to size, position between vertical Strong Posts and secure into position with Internal Fixing Brackets. Internal Fixing Brackets to be located between nibs provided in Aluminium extrusions. It is recommended that factory machine finished Door Stop header sections are used, or alternatively measure opening and cut Door Stop sections to size, check door hand and mitre accordingly (clip Door Stop onto loose piece of Strong Post, holding into position for an accurate mitre before cutting). Bubble Seal Gasket to be located into position on Door Stop sections before installation. Clip Door Stop sections into Strong Posts/ Main Posts. Position Finesse Hinge and screw/pop rivet into position, screw/pop rivet to be long enough to reach central web of Strong Post. For full height doors it is recommended that a Timber Packer be used behind Hinges. Cut hole for Lock Box and fix Lock Box into position. For standard door with panel above, it is recommended that panel above door be glazed. Refer to Door Frame details on page 25.

Glazing

A: Preparation

Position Main Post vertically from floor to underside of top Main Post, secure to floor and to top Main Post with Internal Fixing Brackets. For full height glazing, secure Main Post on floor with Internal Fixing Brackets, between vertical Main Posts, open section to face down.

For half glazed panels secure Main Post at level required, between vertical Main Posts. Internal Fixing Brackets to be used to secure sections together.

B: Finishing

Refer to Step 1 and Step 2 below (horizontal glazing sections to be installed first.)

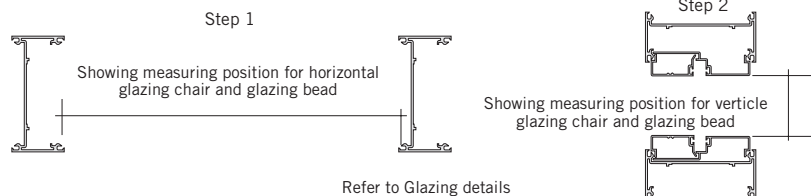

SPECIFICATIONS

C: Glass

The Lafarge Finesse® Remountable Partition System clip in glazing sections, including the Bubble Seal Gasket, have been designed to accept glass from 4mm to 6mm nominal thickness. Where thicker glass is installed, the Bubble Seal Gasket to the Glazing Chair can be omitted. Alternatively, Woodpile can be installed instead of the Bubble Seal Gasket.

Complementary Accessories

A full range of complementary accessories are available in the form of Rounded 90° Corner Post, 135°/45° Corner Post, 3 Way Box Post, 3 Way "Y" Post, 4 Way Box Post, including a full range of moulded Capping Pieces to close open ends of Aluminium sections in low level applications. Various configurations using the full range of add-on fittings are available. When used in a partition wall application, these sections to run full height floor to ceiling. Refer to Junction Accessories.

Aluminium

All Aluminium sections are extruded from grade 6063 Architectural Aluminium available in Mill, Anodized or Powder coated finishes.

Power Skirting

Power Skirting Sections are available in Aluminium which complement the Lafarge Finesse® Remountable Partition System.

- 1: Floor or Transom fixed within partition thickness.
Refer to page 41.
- 2: Wall mounted 60mm deep Power Skirting. Die 6420.
Wall Finishes

A range of Vinyls are available, please contact our branches for details.

Low Level Movable Office Partition

Due to the flexibility and range of accessories available in the Lafarge Finesse® Remountable Partition System, low level movable office partitions can easily be assembled.

Lafarge Finesse® Remountable Partition System.

Supply and install Lafarge Finesse® Remountable Partition System from Lafarge Gypsum with overall thickness of 88mm comprising of internal framing formed of 48mm Finesse® galvanised steel studs clipped into position at 600mm centres into Finesse® galvanise steel friction track top and bottom, including where necessary, any additional Finesse® steel friction track to be secured to aluminium door openings, glazing, angles corners, head, termination and floor.

The internal steel framing is to be dressed both sides with 12mm thick 1 195mm wide pre-laminated square edge Lafarge plasterboard (specific finish) in single lengths to suite height and secured to the Finesse® steel studding with galvanised steel clamping strips finished with aluminium clip-on cover trim. All exposed aluminium, head sections, wall sections, glazing sections, door frames, corner sections, cover trims, clip-in glazing, clip-in door and skirting are to be formed of (natural anodized/colour anodized/power coated to specific colour, aluminium sections. Maximum height of 3 600mm.





LAFARGE COMPOUNDS



Lafarge Jointing Plaster

Description

Lafarge Jointing Plaster is a jointing compound used together with fiba tape at the tapered edge joints of Lafarge plasterboards.

Features

- It provides ease of application
- Special additives within its body delays the absorption of joint water by the plasterboard surface
- It has a filler function which creates a smooth surface finish due to special grain distribution
- It has high binding features
- It has a flexible feature which eliminates the chance of cracking on the joints and therefore enables the application surface to work uniformly
- Since it is a breathing material, it creates a healthy atmosphere by balancing the moisture rate

Specifications

Water/Plaster Mixing Ratio:	6-6.5L water to 10kg
Working Time:	60 minutes
Setting Time:	115 – 145 minutes
Shelf Life:	1 year
Coverage Ratio:	40lm per 20kg bag (based on 2 coats)
Packaging Colour:	Dark Orange
Use:	Internal only

Mixing Instructions

1. Use clean water in a clean container
2. Slowly pour Lafarge Jointing Plaster Premium into clean water
3. Allow Lafarge Jointing Plaster Premium to stand/soak for 2 minutes before mixing
4. Mix the mortar to obtain lump free smooth paste
5. Do not over stir
6. Do not mix with your hands
7. Clean tools and mixing container after each mix
8. Do not mix more Lafarge Jointing Plaster Premium then you can use in 60 minutes

Application Instructions

- Apply Lafarge Jointing Plaster Premium to a clean dust free surface
- Apply product to plasterboard joints to specification

Recommendations

- Use low-speed mechanical mixer or mix manually
- Do not add any water or plaster to the mortar after mixing
- Do not apply when temperature is below 5°C and above 40°C
- Never mix Lafarge Jointing Plaster Premium with any other product or material
- Lafarge Jointing Plaster Premium – Pre-filling should be done to the joints that are wider 3mm

Lafarge Jointing Plaster Standard

Description

Lafarge Jointing Plaster Standard is a jointing compound used together with fiba tape at the tapered edge joints of all Lafarge plasterboards.

Features

- It provides ease of application
- Special additives within its body delays the absorption of joint water by the plasterboard surface
- It has a filler function which creates a smooth surface finish due to special grain distribution
- It has high binding features
- Since it is a breathing material, it creates a healthy atmosphere by balancing the moisture rate.

Specifications

Water/Plaster Mixing Ratio	2 parts powder to 1 part water by weight
Working Time	70 – 130 minutes
Setting Time	115 – 145 minutes
Shelf Life	6 months
Packaging	20kg
Coverage Ratio	40lm per 20kg (based on 2 coats)
Packaging Colour	Orange
Use	Internal only

Mixing Instructions

1. Use clean water in a clean container
2. Slowly pour Lafarge Jointing Plaster Standard to water in a mixing ratio of 2 parts powder to 1 part water by weight
3. Allow Lafarge Jointing Plaster Standard to stand/soak for 2 minutes before mixing
4. Lafarge Jointing Plaster Standard can be mixed by hand or by an electric whisk
5. Mix for 2 - 3 minutes until a creamy paste is achieved
6. Do not over stir
7. Do not mix with your hands
8. Clean tools and mixing container after each mix
9. Do not mix more Lafarge Jointing Plaster Standard then you can use in 50 minutes

Application Instructions

- Apply Lafarge Jointing Plaster Standard to a clean dust free surface
- Apply over fiba tape

Recommendations

- Use low-speed mechanical mixer or mix manually
- Do not add any water or plaster to the mortar after mixing
- Do not apply when temperature is below 5°C and above 40°C
- Never mix Lafarge Jointing Plaster Standard with any other product or material
- Lafarge Jointing Plaster Standard – Pre-filling should be done to the joints that are wider 3mm

Lafarge Finishing Plaster

Description

The Lafarge Finishing Plaster is an under-paint final layer finishing plaster with high adhesive characteristics on Lafarge plasterboard apply fiba tape to joints

Features

- The Lafarge Finishing Plaster is used to make any type of wall and Lafarge plasterboard surface ready to paint
- The long usage period allows easy and faultless application
- Special additives used in its body delays the Lafarge Finishing Plaster mortars water to be absorbed from the existing ground
- It has a puffy form which makes for ease of application
- It provides a hard and smooth surface due to its special grain distribution
- Since it is a breathing material, it creates a healthy atmosphere by balancing the moisture rate
- It makes for easy use in humid environments

Specifications

Water/Plaster Mixing Ratio:	6,5 – 7l water to 10kg
Working Time:	60 minutes
Setting Time:	Starts within 20 minutes
Shelf Life:	1 year
Packaging:	25kg
Application Thickness:	1 to 3 mm
Coverage Ratio:	1kg for 1mm of application per m ²
Packaging Colour:	Purple
Use:	Internal only

Mixing Instructions

1. Use clean water in a clean container
2. Slowly pour Lafarge Finishing Plaster into cold clean water
3. If using a deep mixing container saturate the water with Lafarge Finishing Plaster
4. Allow Lafarge Finishing Plaster to stand/soak for 2 minutes before mixing
5. Mix to obtain homogenous mix with no lumps and a smooth paste
6. Do not over stir
7. Do not mix with your hands
8. Clean tools and mixing container after each mix
9. Do not mix more Lafarge Finishing plaster then you can use in 60 minutes

Application Instructions

- Apply Lafarge Finishing Plaster to a clean dust free surface
- Apply paste to area with trowel to specified thickness
- Polish
- For 1mm of application per 1m² approximately 1kg of Lafarge Finishing Plaster is consumed

Recommendations

- Use low-speed mechanical mixer or mix manually
- Do not add water or plaster to the mortar after mixing
- Do not apply when temperature is below 5°C and above 40°C
- Never mix Lafarge Finishing Plaster with any other product

Lafarge Skimming Compounds

Fields of Use

Interior Areas

- Plasterboard Ceilings
- Plasterboard Walls
- Cement Rendered Walls
- Brick walls

Description:

The Lafarge Skimming Compounds are used as finishing compounds in skim finish and can be applied for internal use only.

Lafarge Skim Stone

Specifications

Water/Plaster Mixing Ratio	Add in Lafarge Skim Stone to clean water. Allow to soak Stir slowly to a lump free mixture
Working Time	60 to 90 minutes
Setting Time	90 to 120 minutes
Shelf Life	6 months
Packaging	33kg
Coverage Ratio	1-3mm – 18m ² , 5-6mm – 10m ² 12-13mm – 3m ² (per 33k bag)
Application Thickness	1 to 13mm
Packaging Colour	Yellow
Use	Internal only

Mixing Instructions

1. Use clean water in a clean container
2. Slowly pour Lafarge Skim Stone/Lafarge Skim Lite Plaster into clean water and saturate the water
3. Allow Lafarge Skim Stone/Lafarge Skim Lite Plaster to stand/soak before mixing
4. Mix to obtain homogenous mix with no lumps and a smooth paste
5. Do not over stir
6. Do not mix with your hands
7. Clean tools and mixing container after each mix
8. Do not mix more Lafarge Skim Stone/Lafarge Skim Lite plaster then you can use in 90 minutes

Lafarge Skim Lite

Specifications:

Water/Plaster Mixing Ratio	Add in Lafarge Skim Stone to clean water. Allow to soak Stir slowly to a lump free mixture
Working Time	45 to 60 minutes
Setting Time	90 to 120 minutes
Shelf Life	6 months
Packaging	40kg
Coverage Ratio	1-3mm – 22m ² , 5-6mm – 12m ² 12-13mm – 4m ² (per 40kg bag)
Application Thickness	1 to 13mm
Packaging Colour	Blue
Use	Internal only

Application Instructions

- Apply Lafarge Skim Stone/Lafarge Skim Lite Plaster to a clean dust free surface
- Apply paste to area with trowel to specified thickness (recommended 1-3mm)
- Polish
- For best results on concrete/cement plastered wall
 - Clean of loose dust particles and moisture
 - Apply water base sealer to surface
 - Allow to dry
 - Apply Lafarge Skim Stone/Lafarge Skim Lite
 - Allow to dry
 - Coat with Sealer "impregnated white" as base coat
 - Paint with water based paint

Recommendations

- Lafarge Skim Stone – utilising 15/17 litres of water in a clean container, add 33kg of Lafarge Skim Stone
- Lafarge Skim Lite – utilising 20/22 litres of clean water in a clean container, add 40kg of Lafarge Skim Lite
- Do not apply when temperature is below 5°C and above 40°C



Lafarge Gypsum SA (Compounds)

Application	Plasterboard Joints	Fiba Tape	Full Skim	Plaster Board	Cement Surface	Bonding Agent	Brick Surface	Bonding Agent	Painted Surface	Bonding Primer	Paint Application	Paint Primer	
													PVA Solvent
Premium Jointing Plaster	✓	✓									✓	✓	✓
Standard Jointing Plaster	✓	✓									✓	✓	✓
Finishing Plaster		✓	✓	✓	✓	✓	✓	✓	✓	✓	✓	✓	✓
Skim Stone Plaster		✓	✓	✓	✓	✓	✓	✓	✓	✓	✓		✓
Skim Lite Plaster		✓	✓	✓	✓	✓	✓	✓	✓	✓	✓		✓

**ALL LAFARGE GYPSUM COMPOUNDS
ARE ECOSPECIFIER LISTED.**



LAFARGE GYPSUM BUILDING SOLUTIONS FOR LIFE



BRANCHES

GAUTENG BRANCHES

Head Office

18 Barium Street, Alrode Ext 7, 1450
PO Box 167025, Brackendowns, 1454
Tel: (+27 11) 389 4500
Fax: (+27 11) 864 6816

Roodekop

4 Berry Road, Roodekop
PO Box 167025
Brackendowns, 1454
Tel: (+27 11) 865 2390
Fax: (+27 11) 865 2398
Branch Manager: Cheryll van Onselen

East Rand

Jamela Park, No. 60 Denne Road
Hughes Ext 21, Boksburg
Tel: (+27 11) 826 1707
Fax: (+27 11) 826 1708
Branch Manager: Riana van Staden

Pretoria

12A Church Street, Pretoria Central, 0001
PO Box 48159, Hercules, 0030
Tel: (+27 12) 325 2408
Fax: (+27 12) 325 2409
Branch Manager: Sonja Francis

Pretoria East

219B Battery Street, Willows Business
Park, Silverton, Pretoria, 0127
Tel: (+27 12) 803 1772
Fax: (+27 12) 803 1779
Branch Manager: Patrys Joerning

Troyeville

No. 24th Street, Doornfontein, Johannesburg
Tel: (+27 11) 402 4747
Fax: (+27 11) 402 4749
Branch Manager: Potiphar Esau

Wynberg

Cnr Andries North & Chadwick Street
Wynberg, Sandton
Tel: (+27 11) 444 8020
Fax: (+27 11) 444 8077
Branch Manager: Ronald Moffatt

COASTAL BRANCHES

Cape Town

34B Cochrane Avenue, Lovemore Complex
Gunnars Circle, Epping 1
Cape Town, 7405
PO Box 68, Epping, 7405
Tel: (+27 21) 534 2039
Fax: (+27 21) 534 1803
Branch Manager: Terence Domingo

Durban

Unit 4 & 5 Grid Height Office Park,
No. 11 River Horse Close, River Horse Valley
Branch Manager: Alan Rayne
Cell: 082 773 2115
Sales Representative: Gerhard Mey
Cell: 082 783 5058

George

PW Botha Boulevard, Erf 24964
Steinhoff Industrial Park, George
Tel: (+27 44) 878 1578/1461
Fax: (+27 44) 878 1583
Branch Manager: Jeanne Cahill

Port Elizabeth

Cnr Fettes Road & Harrower Road
North End, PO Box 2788
North End, Port Elizabeth, 6056
Tel: (+27 41) 373 2295
Fax: (+27 41) 373 0075
Branch Manager: Wayne Mulder

INLAND BRANCHES

Bloemfontein

9 Pine Street, Old Industrial Area
Bloemfontein, 9300, PO Box 692
Bloemfontein, 9300
Tel: (+27 51) 447 1024
Fax: (+27 51) 447 1074
Branch Manager: Mario Lategan

Nelspruit

8 Silva Street, West Acres, Ext 11
Nelspruit, PO Box 706, Nelspruit, 1200
Tel: (+27 13) 752 2129
Fax: (+27 13) 752 2160
Branch Manager: Haley Lewis

Polokwane

86 Silicon Street
Ladina, Polokwane, 0742
Tel: (+27 15) 293 2985/83/26
Fax: (+27 15) 293 2928
Branch Manager: Coenie Engelbrecht

EXPORT BRANCHES

Botswana

Plot 22016 Unit B & C, Gaborone, West
Industrial, Private Bag 003, Suite 466
Mogoditsshane, Botswana
Tel: (00 267) 316 7732/34
Fax: (00 267) 316 7753
Admin Branch Manager: Reginah Kapembwa

Maputo

Rua Das Estancias 344, Warehouse 3 & 4
Maputo, Moçambique
Tel: 00 258 (1) 31 0063
Fax: 00 258 (1) 31 0068
Branch Manager: Ellah Jeyacheya



LAFARGE GYPSUM HEAD OFFICE

18 Barium Street, Alrode Ext 7, 1450
PO Box 167025, Brackendowns, 1454
Tel: (+27 11) 389 4500
Fax: (+27 11) 864 6816
Web: www.lafarge.co.za

0861 GYPSUM (497786)