

# Civil Products

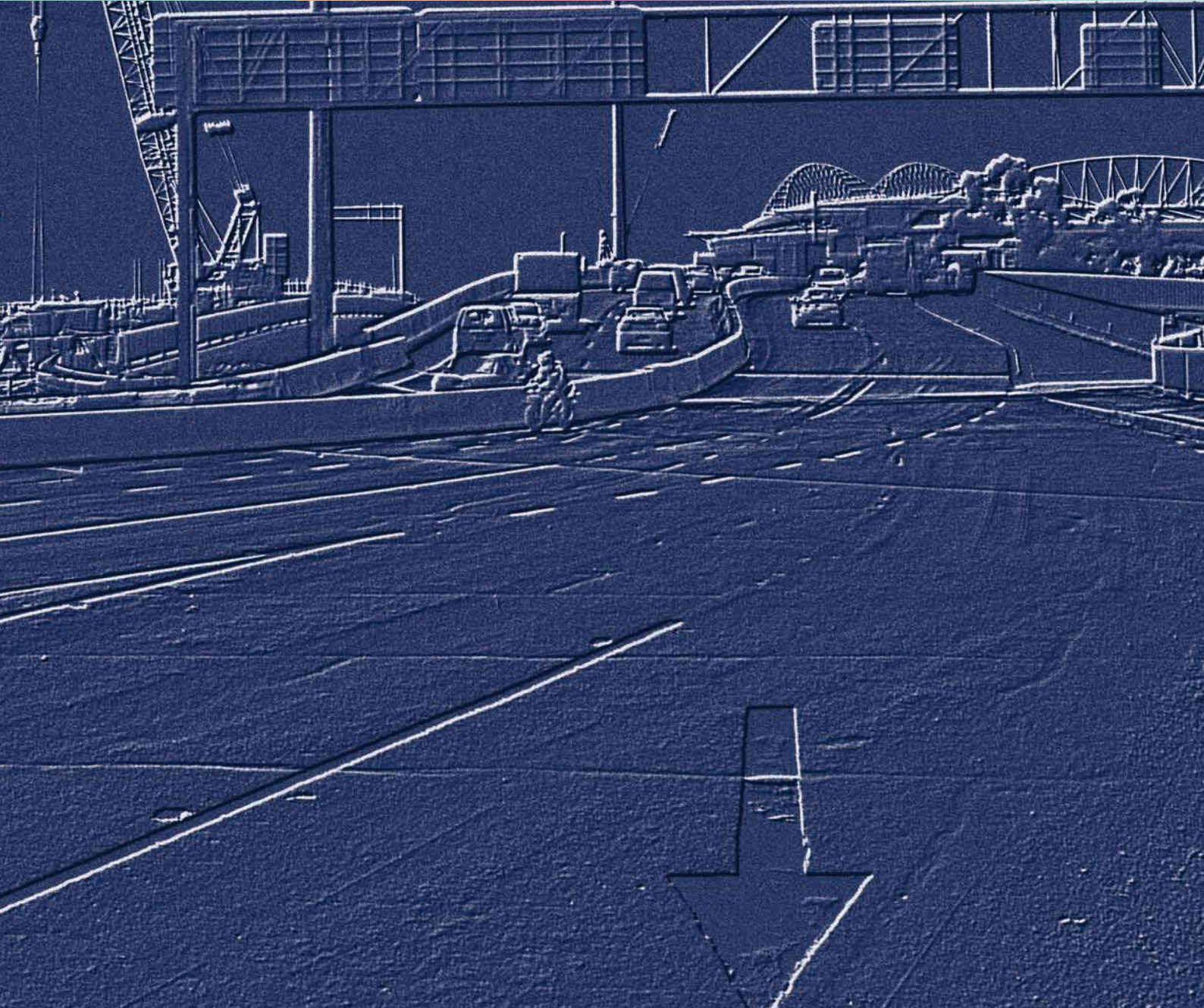
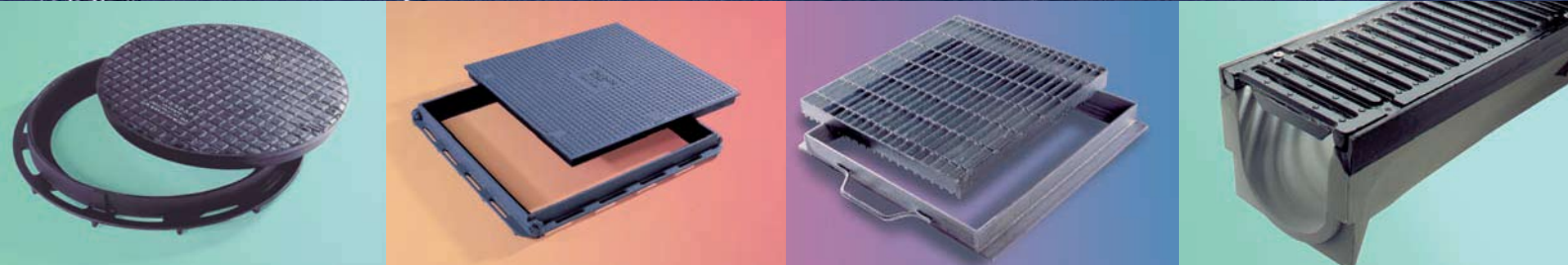

**WEBFORGE**

# The Company

The Webforge Group has in excess of 50 years experience as a specialist manufacturer of metal flooring and allied products to various national and international standards. Manufacturing is undertaken on “state of the art” equipment incorporating computerised and robotic technologies. The company is committed to a continuous process of updating such equipment to enhance customer service through product quality and delivery.

The Webforge Group is committed to meeting the requirements as set down in International Quality Standard ISO 9000 to ensure the supplied product will meet and exceed the customers requirements.

Through its network of operations throughout Australia, New Zealand and Asia, Webforge has the resources and experience to service a complete range of projects, whatever the complexity or size.

## Services

- Manufacture
- Technical Support
- Quality Assurance
- Feasibility and Budget Rates
- Lump Sum and Contract Rate
- Major Projects through to Small Contracts

## Products

- Industrial Flooring, Grating and Stair Treads
- Handrailing, Barriers and Balustrading
- Expanded Metal Mesh Products
- Fabricated Drainage Grates and Cast Access Covers

[www.webforge.com.au](http://www.webforge.com.au)

## General information

- Testing
- AS3996 Strength Classification
- Other requirements of AS3996
- Specifying
- Frame Clear Opening

### Section 1

### Ductile Iron Circular, Square and Rectangular Single Part Covers

1

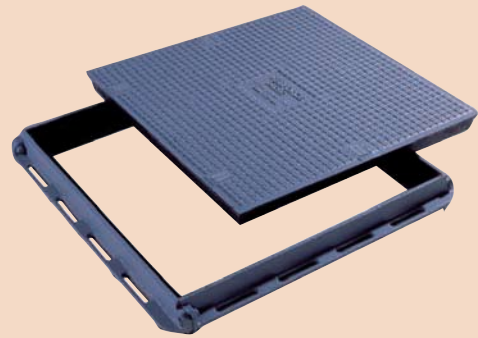

### Section 2

### Fabricated Mild Steel Sump Grates, Trench Grates and Road Grates

2

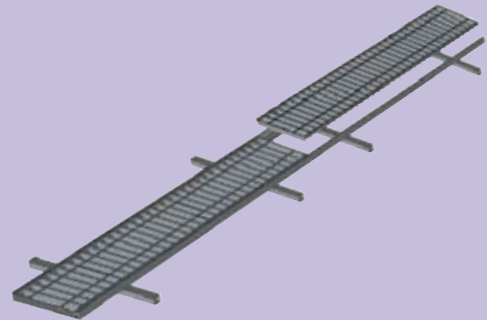

### Section 3

### Glass Reinforced Concrete Channel and Pits

3

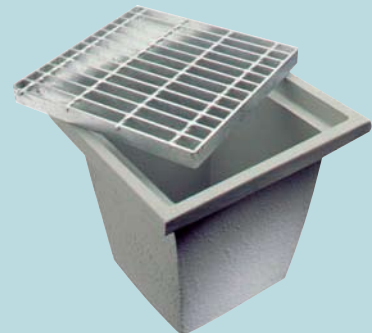

### Testing

Webforge can test in-house Mild Steel Grates and Ductile Iron Access Covers to ensure compliance with the load and permanent set requirements specified in AS3996-2006. Conformance certificates can be supplied upon request. Webforge are also capable of custom manufacturing Mild Steel Grates and Frames to suit specific client applications and load test these according to AS3996-2006 if required.



### AS3996 Strength classifications and the loading conditions applying to these classifications

#### Class A – Serviceability Test Load 6.7kN

Footways and areas accessible only to pedestrians and pedal cyclists (Extra-light Duty).



#### Class B – Serviceability Test Load 53kN

Footways that may be mounted by a vehicle or livestock, and light tractor paths (Light Duty).



#### Class C – Serviceability Test Load 100kN

Malls and pedestrian areas open to slow moving commercial vehicles (Medium Duty).



#### Class D – Serviceability Test Load 140kN

Carriageways of roads and areas open to commercial vehicles (Heavy Duty).



### Other requirements of AS3996

In addition to strength, AS3996 has requirements for gas and water tightness, keyhole dimensions, grate bicycle safety, identification markings, frame dimensions, etc. Where applicable Webforge access covers and drainage grates comply with these requirements.

### Specifying access cover and drainage grate sizes

The industry convention is to identify the size of access covers and drainage grates by specifying the internal clear opening dimensions of the frame. For circular covers this dimension is a diameter. For square and rectangular covers, the normal convention is Width x Length. ( W x L ) For single part covers, the width is taken as the frame dimension parallel to the side of the cover with two keyholes. For single row, multirow and trench grates, the width is taken as the span of the trench.

### Frame Clear Opening Dimensions

The frame clear openings of Webforge access covers and drainage grates are made to be 15mm larger than the nominal sizes of industry standard sized pits.

This has been done to allow frames to be placed over standard panel formwork and cast in while pouring the pit walls. This speeds up installation and ensures the frame is fully embedded in the concrete.

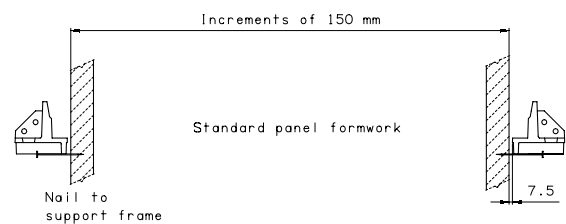

### Special Features – "New"

- Snap-lok

Circular covers can be supplied with Snap-lok as an alternative to Holding down bolts. Snap-lok is a pin and groove arrangement which also provides resistance to back pressure or unauthorised opening.

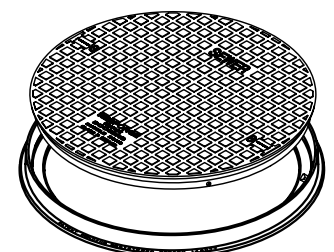
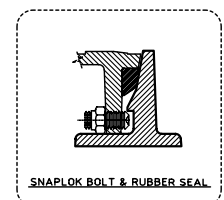

## Cast In Circular Covers

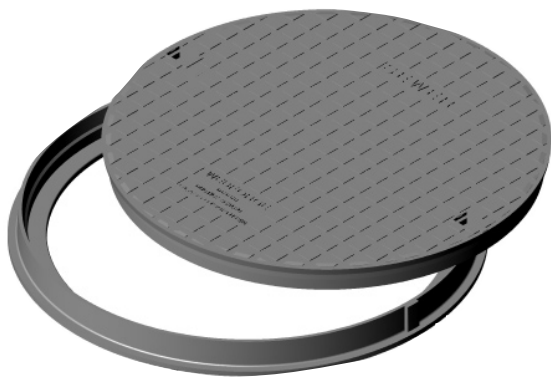

**Strength Class B**

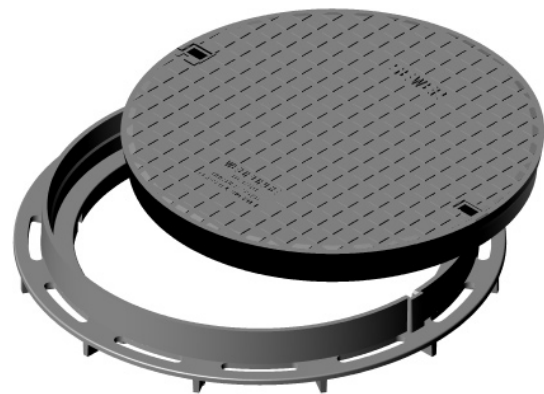



**Strength Class D**

The unique features of Webforge ductile iron solid top circular access covers provide the following benefits

- Lower weight which means safer handling and greater OH&S advantages
- Elimination of concrete infilling and the need to repair or replace worn concrete

## Product Codes for Circular Covers

AS3996 Strength Classifications				
Frame Clear Opening Diameter (mm)	Class B 53kN  Footways that may be mounted by a vehicle or livestock, and light tractor paths (Light Duty).	Class D 140kN  Carriageways of roads and areas open to commercial vehicles (Heavy Duty).	Weight of Cover Only	Weight of Cover and Frame
615	DCC6B		28kg	42kg
615		DCC6D	55kg	90kg



All Webforge covers are cast from 500/7 ductile iron to AS1831 giving greater strength and durability than other designs utilising T220 grey iron.

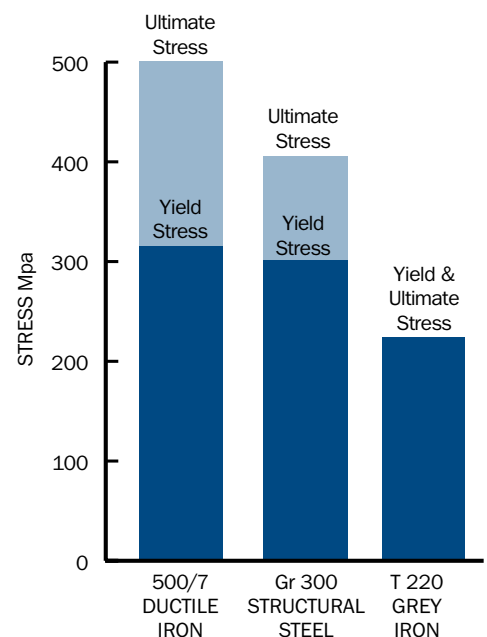

## Sewer Maintenance Shaft Covers

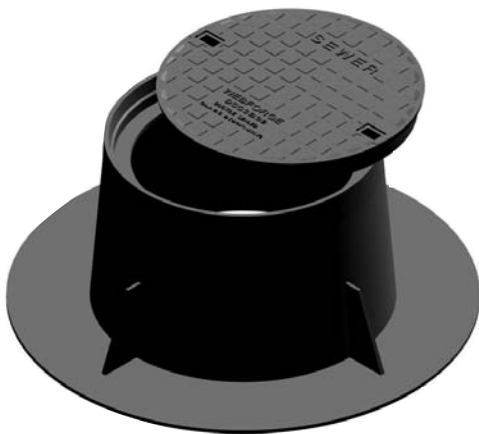

DCC3B32

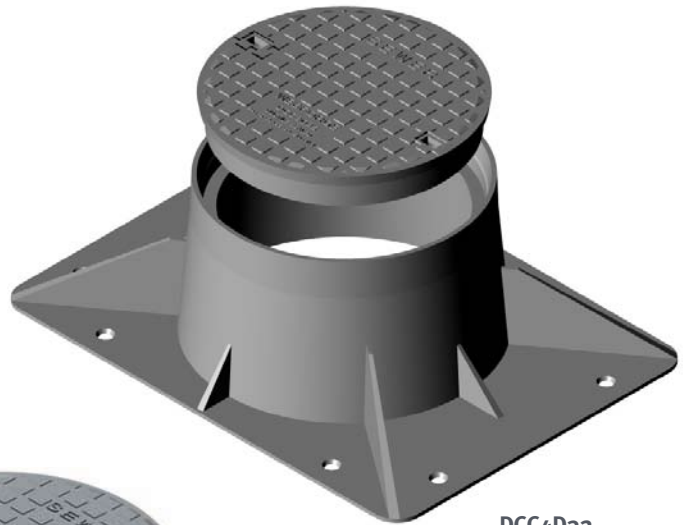

DCC4D32

• Registered Design 146697

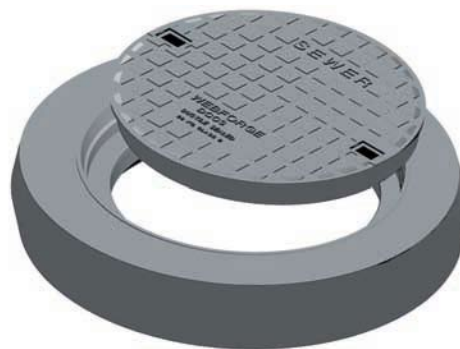



DCC3BPCE

120 mm deep concrete encased frame

• Registered Design 135988

## Product Codes for Sewer Maintenance Shaft Covers

### AS3996 Strength Classifications

Frame Clear Opening Diameter (mm)	Frame Depth	Class B 53kN  Footways that may be mounted by a vehicle or livestock, and light tractor paths (Light Duty).	Class D 140kN  Carriageways of roads and areas open to commercial vehicles (Heavy Duty).	Weight of Cover only	Weight of Cover and Frame
370	325	DCC3B32		14kg	59kg
370	84	DCC3BP		14kg	30kg
370	120	DCC3BPCE		14kg	75kg
432	325		DCC4D32	31kg	107kg

### Typical Details

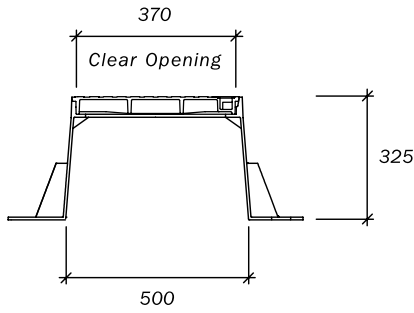

**DCC3B32**

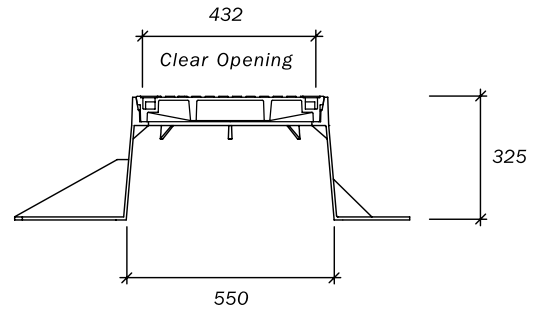

**DCC4D32**

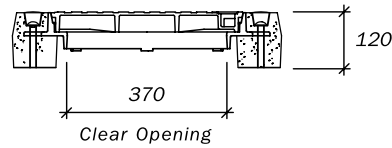

**DCC3BPCE**

### Installation Guide

Support beams can be:

- 1 Timber
- 2 Concrete
- 3 Galvanised angle

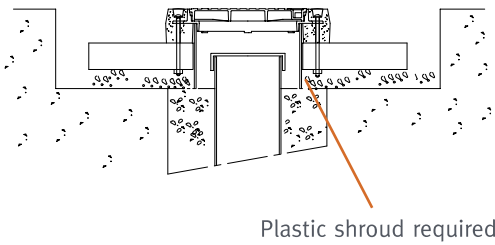

**DCC3BPCE**

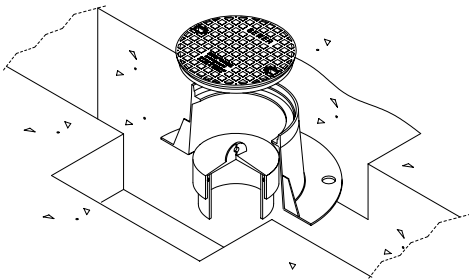
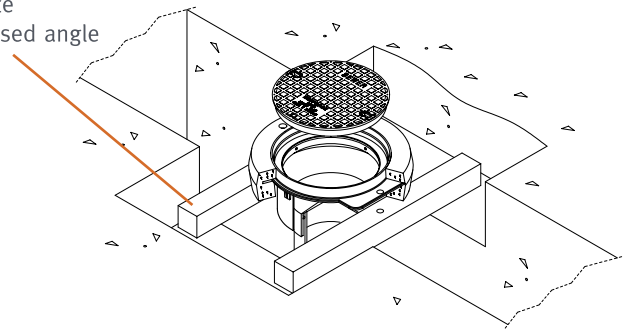

**DCC3B32**  
Concrete encasement  
not required

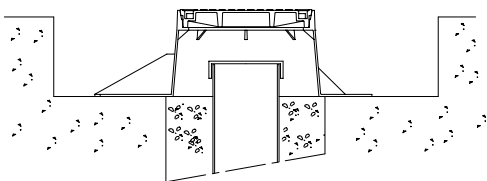
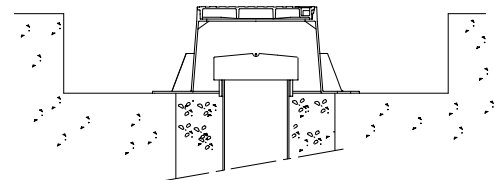

**DCC4D32**  
Concrete encasement  
not required

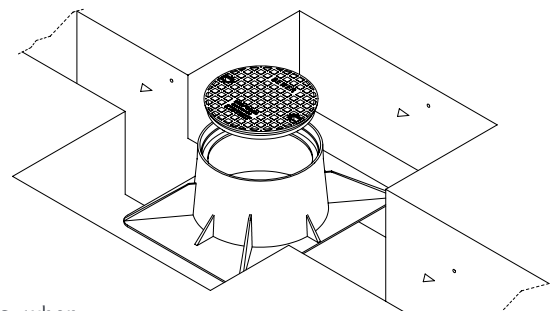

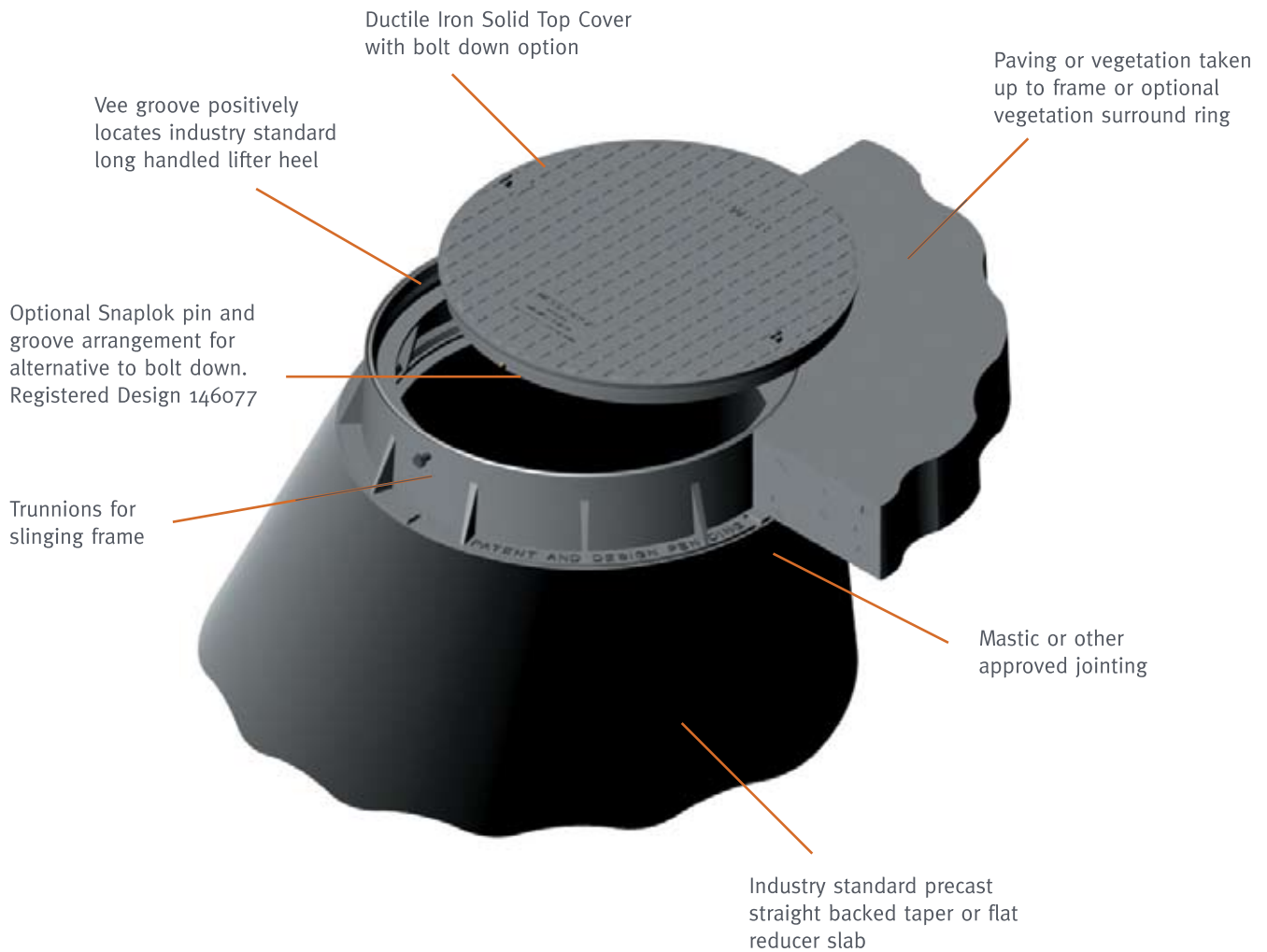

Deep frame chambers eliminate the need for a plastic shroud. Wide flanges, when bedded on granular material eliminate the need for supporting beams or slabs.

## Precast Sewer Access Chamber Covers



## Product Codes for Precast Sewer Access Chamber Covers

AS3996 Strength Classifications				
Frame Clear Opening Diameter (mm)	Class B 53kN  Footways that may be mounted by a vehicle or livestock, and light tractor paths (Light Duty).	Class D 140kN  Carriageways of roads and areas open to commercial vehicles (Heavy Duty).	Weight of Cover Only	Weight of Cover and Frame
615	DCC6BPAC		28kg	59kg
615		DCC6DIPAC	43kg	74kg

### Registered Design

- 153559
- 153584

### Patent Pending

Installation Procedures Available Upon Request from your Local Webforge Branch

## Single Part Covers

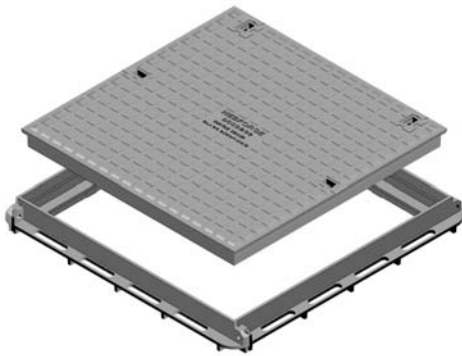

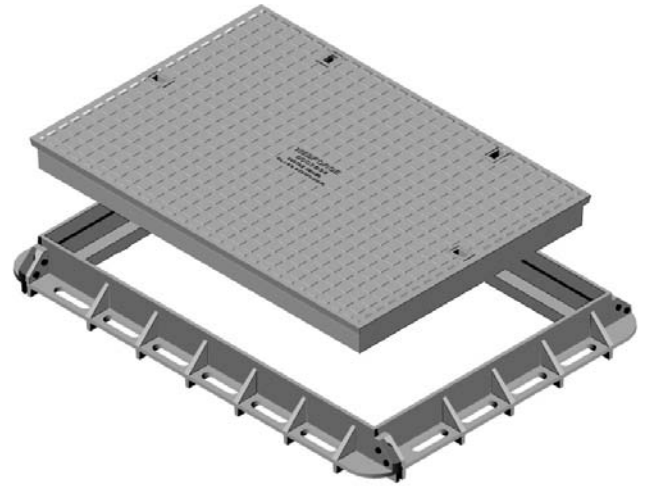

**Strength Classes AB**



**Strength Class CD**

## Product Codes for Single Part Covers

### AS3996 Strength Classifications

Frame Clear Opening	Class A B 53kN		Class C D 140kN			
	Footways that may be mounted by a vehicle or livestock, and light tractor paths (Light Duty).		Carriageways of roads and areas open to commercial vehicles (Heavy Duty).			
	Codes	Weight		Codes	Weight	
		Cover Only	Cover and Frames		Cover Only	Cover and Frames
465 x 465	DRC44AB	24kg	36kg	DRC44CD	30kg	50kg
615 X 615	DRC66AB	35kg	50kg	DRC66CD	45kg	70kg
915 X 615	DRC96AB	50kg	69kg	DRC96CD	65kg	96kg
915 X 915	DRC99AB	84kg	106kg	DRC99CD	95kg	131kg



Patent Pending  
Registered Design 142426



All Webforge access covers and drainage grates comply with the requirements of AS3996 – Metal Access Covers Road Grates and Frames.

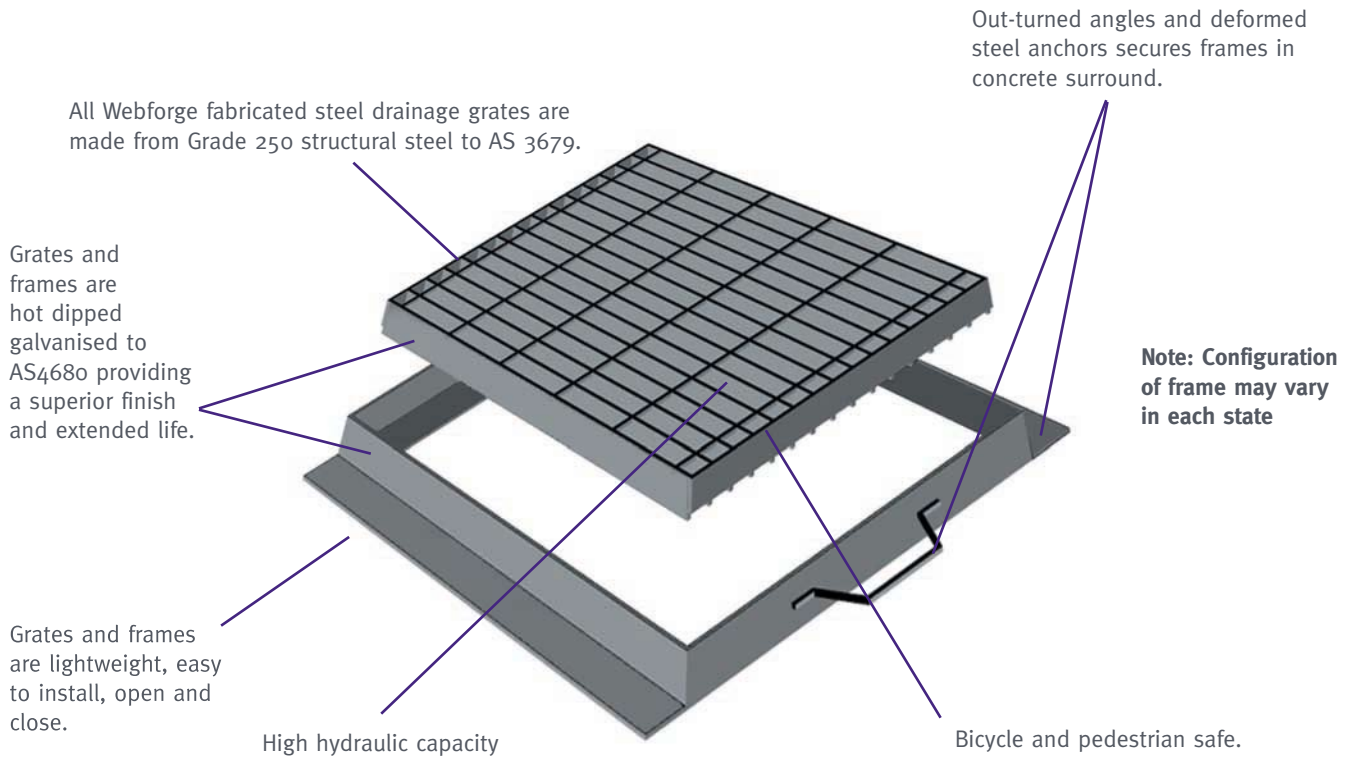

## Optional Extras

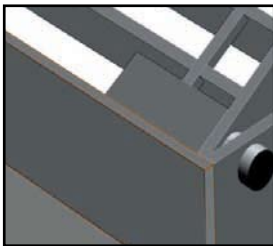

Hinging to prevent theft and accidental dropping of grate

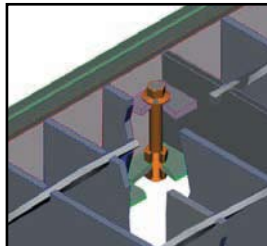

Holding down bolts to prevent unauthorised entry



## Sump Grates

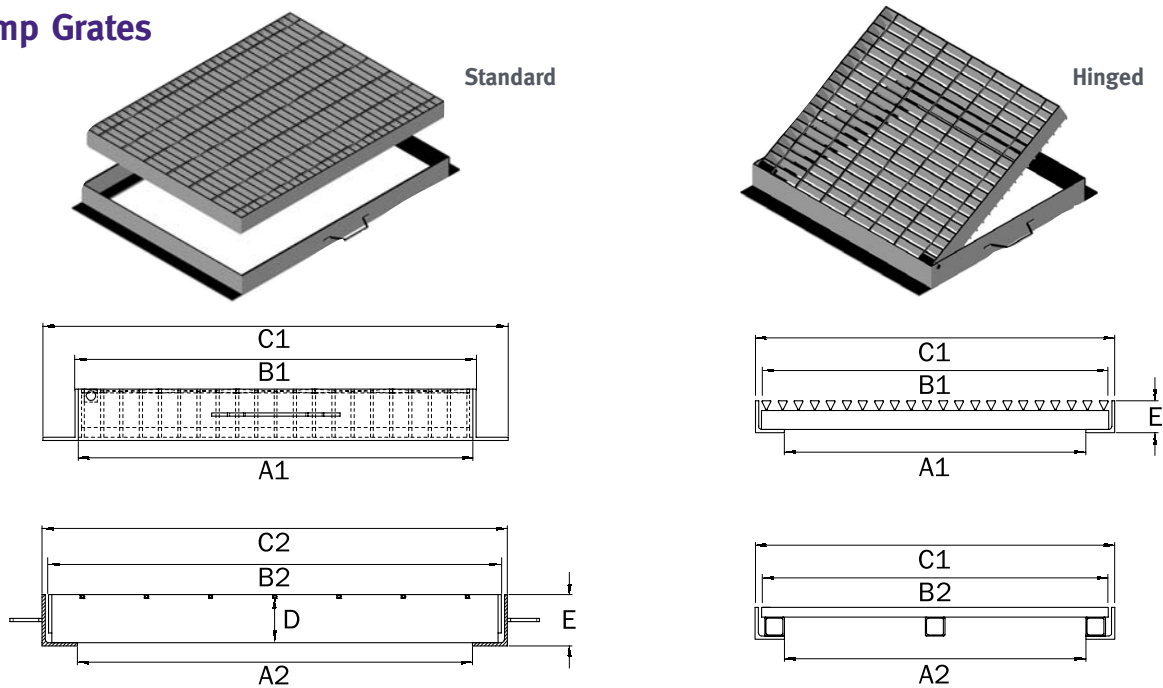

Standard Grating Class B, C, D

Ezi - Walk Class A

Drawing Number	Class AS3996	kg/ea	Clear Opening	Grate Size	Frame Overall	Grate Depth	Frame Depth	Type
MSG15B	B	3	165 x 155	155 x 185	215 x 205	20	25	Grating
MSG33A	A	7	303 x 303	297 x 347	363 x 363	25	30	Eziwalk
MSG33B	B	11	315 x 315	305 x 375	395 x 395	32	40	Grating
MSG33C	C	13	315 x 315	305 x 395	415 x 415	45	50	Grating
MSG44A	A	16	451 x 451	445 x 525	541 x 541	40	45	Eziwalk
MSG44B	B	27	465 x 465	455 x 545	565 x 565	45	50	Grating
MSG44C	C	40	465 x 465	455 x 539	565 x 565	65	75	Grating
MSG44D	D	45	465 x 465	456 x 555	575 x 575	75	80	Grating
MSG46A	A	22	605 x 451	599 x 525	695 x 541	40	45	Eziwalk
MSG46B	B	34	615 x 465	605 x 545	715 x 565	45	50	Grating
MSG46C	C	53	615 x 465	605 x 539	715 x 565	65	75	Grating
MSG46D	D	63	615 x 465	606 x 555	725 x 575	75	80	Grating
MSG66A	A	27	605 x 605	599 x 678	695 x 695	40	45	Grating
MSG66B	B	45	615 x 615	605 x 705	725 x 725	50	55	Grating
MSG66C	C	62	615 x 615	605 x 689	715 x 715	65	75	Grating
MSG66D	D	73	615 x 615	606 x 705	725 x 725	75	80	Grating
MSG69B	B	63	915 x 615	905 x 705	1025 x 725	50	55	Grating
MSG69C	C	85	915 x 615	905 x 689	1015 x 715	65	75	Grating
MSG69D	D	102	915 x 615	906 x 705	1025 x 725	75	80	Grating
MSG99B	B	115	915 x 915	905 x 989	1015 x 1015	65	75	Grating
MSG99C	C	140	915 x 915	906 x 1005	1025 x 1025	75	80	Grating
MSG99D	D	177	915 x 915	915 x 99	1065 x 1065	100	106	Grating

### EZI-WALK Class C Sump Grates and Frames - Heel Safe 10mm Gap with 15mm Wide Bar

MSG44CE	C	37	450 x 450	444 x 535	550 x 550	85	65	-
MSG66CE	C	60	605 x 605	599 x 689	705 x 705	85	65	-
MSG69CE	C	80	605 x 905	689 x 899	705 x 1005	85	65	-

### Surcharge Pit Hinged Grate and Frame on 100mm Legs - Heavy Duty

MSG66HSC	C	21	705 x 690	670 x 775	775 x 800	50	55	Grating
MSG69HSC	C	36	1025 x 690	990 x 775	1095 x 800	50	55	Grating
MSG99HSC	C	82	1025 x 990	990 x 1075	1095 x 1100	50	55	Grating

### Road Drainage Grates

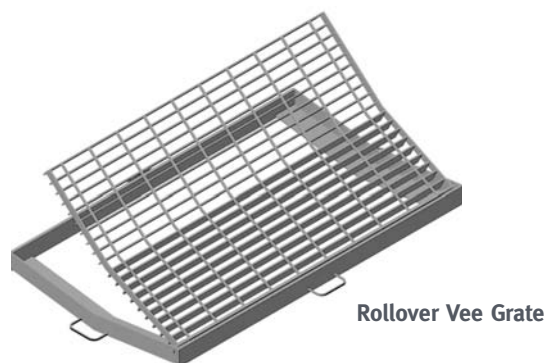

Rollover Vee Grate

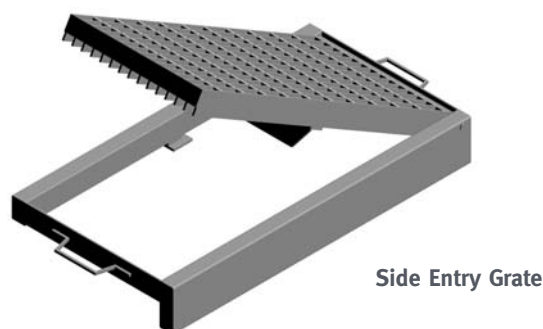

Side Entry Grate

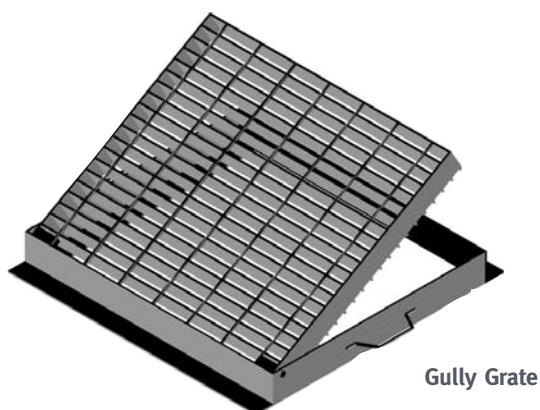

Gully Grate

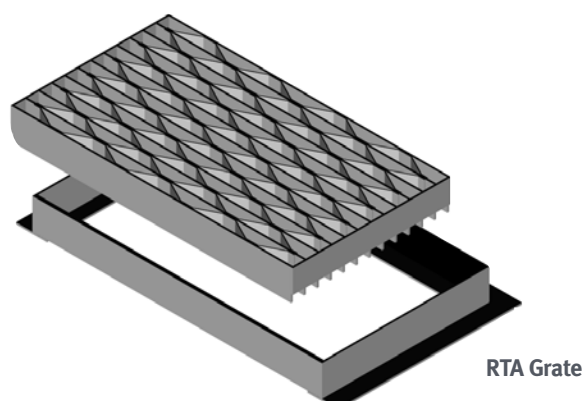

RTA Grate

Webforge manufacture road drainage grates for each authority in each state, please speak to your local branch for details specific to your area.

The Webforge range of gully grates and kerb and channel grates includes a total of 48 local government and state road authority specific designs. The design differences include straight or diamond pattern cross bars, dished or flat top surfaces, plain or hinged, bolted or unsecured.

Product Code	Class AS3996	kg/ea	Clear Opening	Grate Size	Frame Overall	Grate Depth	Frame Depth	Type
MGG47CHSE	C	40	430 x 720	425 x 790	445 x 820	65	75	Grating
MGG48RTASA	D	105	480 x 840	910 x 514	1040 x 592	100	106	Diamond
MGG66DRTAMG	D	112	600 x 600	665 x 726	698 x 750	75	80	Grating
MGG74DH	D	51	745 x 445	725 x 504	755 x 545	65	75	Grating
MGG77DRTASK	D	116	700 x 700	850 x 785	892 x 810	75	80	V-grate
MGG77DRTASO	D	112	700 x 700	720 x 785	765 x 810	75	75	V-grate
MGG94DH	D	62	900 x 445	875 x 504	910 x 545	65	75	Kerb
MGG94HH15	C	61	440 x 930	425 x 985	540 x 1035	65	75	Grating
MGG94HH5	B	45	390 x 925	365 x 954	450 x 1025	65	75	Kerb
MGG94HH5SK	B	47	390 x 956	365 x 954	450 x 1056	65	75	Kerb & skirt
MGG94HH7	B	52	440 x 900	425 x 975	495 x 1035	65	75	Kerb
MGG94HV21	B	57	400 x 900	462 x 1000	474 x 1030	65	75	V-grate
MGG94XHH17	B	103	495 x 965	486 x 1032	596 x 1100	75	80	Grating
MGG94XHH6	D	66	400 x 925	365 x 965	450 x 1035	75	80	Kerb
MGG95HHV20	B	69	530 x 920	514 x 980	641 x 1020	65	75	V-grate
MGG96HHV12	B	77	600 x 935	570 x 1000	620 x 1035	65	75	V-grate
MGG98HHV10	B	96	830 x 900	790 x 975	930 x 1005	65	75	V-grate
MGG104DH	D	73	1075 x 445	1055 x 504	1085 x 545	65	75	Grating
MGG12RTASF	-	32	-	140x30Plx1250	-	-	-	Plate
MGG94HV27	-	55	490 x 930	2-185 x 990	400 x 1030	65	75	V-grate
MGG94DH6	D	78	400 x 883	365 x 1003	450 x 1035	100	105	Kerb

NOTE: For state specific gully grates refer to the product selection guide for your state.

### Trench Grates

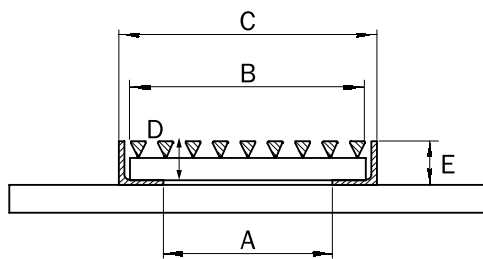
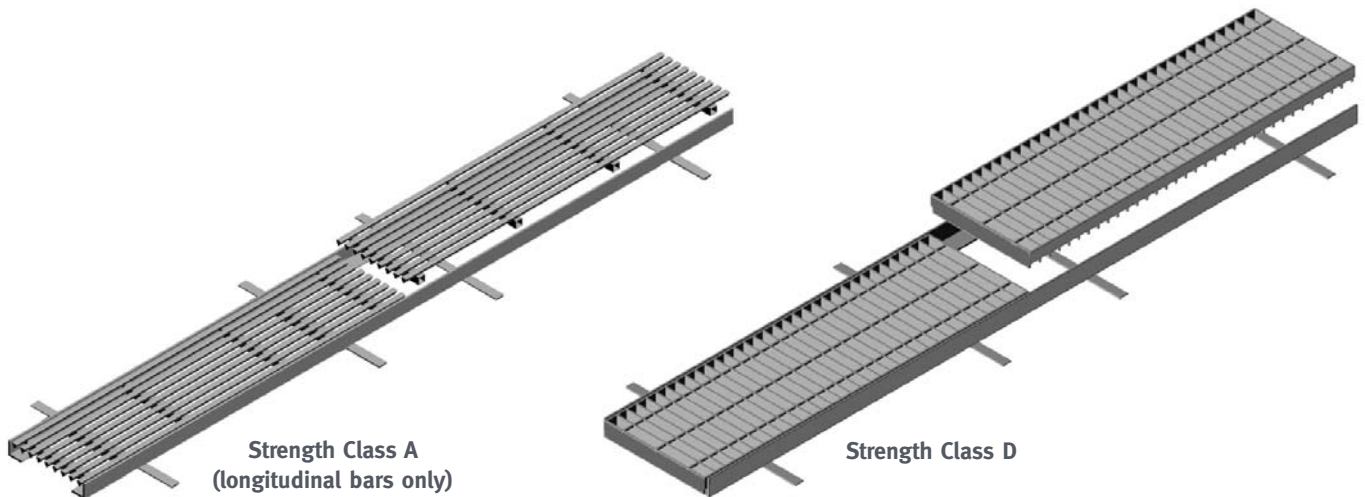

EZI-WALK Class A

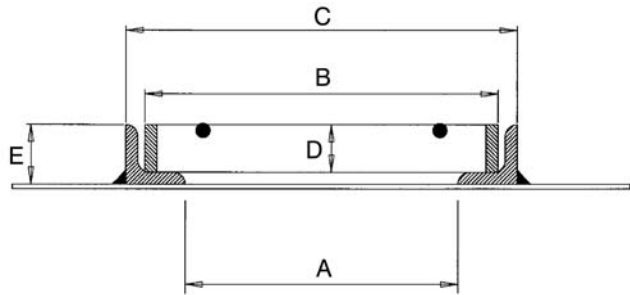

Standard Grating Class B, C & D

Product Code	Class AS3996	Weight kg/lm	Clear Opening	Grate Size	Frame Overall	Grate Depth	Frame Depth	Type
MTG10A	A	15	105	997 x 168	185	35	40	Ezi
MTG10B	B	11	115	995 x 149	165	20	25	Grating
MTG15A	A	16	155	997 x 219	235	35	40	Ezi
MTG15B	B	13	165	995 x 209	225	25	30	Grating
MTG15D	D	26	165	995 x 239	255	40	45	Grating
MTG22A	A	20	232	997 x 296	312	35	40	Ezi
MTG22B	B	19	240	995 x 284	300	25	30	Grating
MTG22C	C	29	240	995 x 314	330	40	45	Grating
MTG22D	D	33	240	995 x 324	340	45	50	Grating
MTG30B	B	27	315	995 x 379	395	32	40	Grating
MTG30C	C	38	315	995 x 399	415	45	50	Grating
MTG30D	D	57	315	995 x 393	415	65	75	Grating
MTG45B	B	50	465	995 x 549	565	45	50	Grating
MTG45C	C	70	465	995 x 543	565	65	75	Grating
MTG45D	D	94	465	996 x 559	575	75	80	Grating
MTG60B	B	67	615	995 x 709	725	50	55	Grating
MTG60C	C	88	615	995 x 693	715	65	75	Grating
MTG60D	D	113	615	995 x 709	725	75	80	Grating

Note: The grate size standards will vary between states. Contact your local branch for standard sizes.  
 WA = 1205, NZ = 905, All other states = 995.

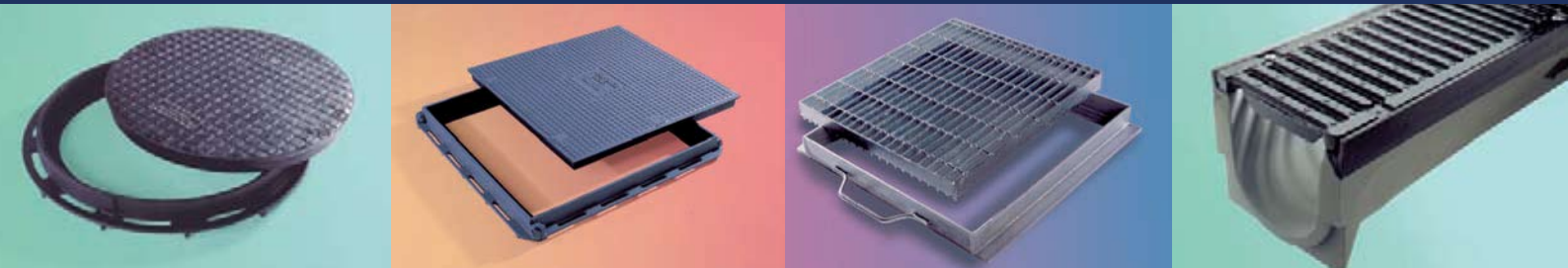

## Australia / New Zealand

### New South Wales

phone (02) 9998 1300  
fax (02) 9998 1340  
email [nsw\\_sales@webforge.com.au](mailto:nsw_sales@webforge.com.au)

### Victoria

phone (03) 8551 2414  
fax (03) 8551 2409  
email [vic\\_sales@webforge.com.au](mailto:vic_sales@webforge.com.au)

### Queensland

phone (07) 3859 8300  
fax (07) 3859 8390  
email [qld\\_sales@webforge.com.au](mailto:qld_sales@webforge.com.au)

### North Queensland

phone (07) 4753 1600  
fax (07) 4729 1899  
email [tville\\_sales@webforge.com.au](mailto:tville_sales@webforge.com.au)

### Western Australia

phone (08) 9373 5100  
fax (08) 9373 5108  
email [wa\\_sales@webforge.com.au](mailto:wa_sales@webforge.com.au)

### New Zealand

phone + 64 6 356 1246  
fax + 64 6 356 7782  
email [nz\\_sales@webforge.co.nz](mailto:nz_sales@webforge.co.nz)

## Brochures also available

Access Products  
Expanded Metal Products  
Planking Products  
Lockline Sunscreens

# [www.webforge.com.au](http://www.webforge.com.au)



### Disclaimer

While Webforge has taken all reasonable care in preparing this brochure, Webforge takes no responsibility for loss resulting from relying on its contents. Customers should make their own enquiries as to whether any products described in this brochure are suitable for their intended use. Information in this brochure may change without notice.

CB Issue 5 04/09